

HUSKY[®]

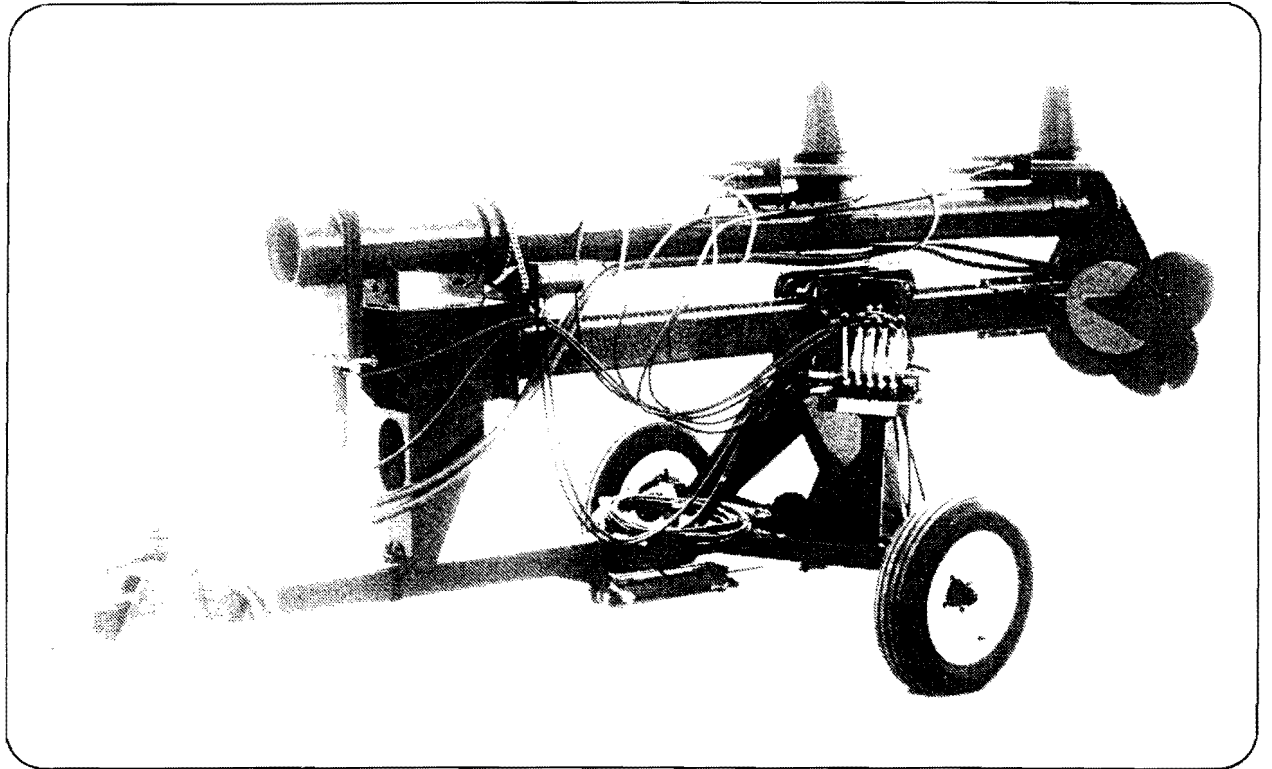

LIQUID MANURE PUMP
H5000/H6000
OPERATOR'S MANUAL

GUARANTEE

All Husky Farm Equipment manufactured by Husky Farm Equipment Limited is guaranteed. Guarantee covers all the replacement cost or repair of all parts said to be defective from manufacture. Guarantee also covers labour installing said parts, if installed at Husky's Manufacturing plant. Time and use is the essence of the guarantee. If equipment is used on a private property for an individual's use, guarantee will be in effect for twelve months from date of invoice. If equipment is used for commercial use to do custom work for money then guarantee will be in effect for three months only from date of invoice.

EXEMPTIONS FROM GUARANTEE

Cost of transportation of equipment to or from Husky Farm Equipment Limited either by customer or by Husky's service staff or cost of mail or of public transportation is not covered. Tires and electric or hydraulic motors are covered by manufacturer's warranty and although Husky may assist to get warranty, Husky will not be responsible other than that allowed by manufacturer's warranty. Items subject to normal wear from use not covered by guarantee if faulty part is simply worn.

TABLE OF CONTENTS

SECTION	DESCRIPTION	PAGE
1	Introduction	01
2	Safety	02
2.01	General Safety	03
2.02	Operating Safety	04
2.03	Maintenance Safety	04
2.04	Hydraulic Safety	05
2.05	Transport Safety	05
2.06	Manure Storage Facility	06
2.07	Storage Safety	06
2.08	Tire Safety	06
2.09	Safety Decals	06
2.10	Sign-Off Form	07
3	Safety Decal Locations	08
4	Operation	09
4.01	To the New Operator Or Owner	09
4.02	How The Machine Works	09
4.03	Break - In	10
4.03.1	Towing	10
4.04	Pre-Operation Checklist	10
4.05	Equipment Matching	11
4.06	Installation Of Pump	12
4.06.1	Trailer Model	12
4.06.2	2 Point Hitch Model	12
4.07	Attaching Accessories	13
4.08	Operation of the H5000/H6000 Pump	13
4.09	Removing the Liquid Manure Pump	14
4.10	Clean-Up	14
4.11	Storage	14
4.11.1	Placing In Storage	14
4.11.2	Removing From Storage	14
5	Service and Maintenance	15
5.01	Service	15
5.01.1	Fluids and Lubricants	15
5.01.2	Greasing	15
5.01.3	Gearbox Service	16
5.01.4	Bearings Service	16
5.01.5	Servicing Intervals	16
5.01.6	Service Record	17
5.02	Maintenance	18
5.02.1	PTO Safety Shield Maintenance	18
5.02.2	PTO Driveline Shear Pin	18
5.02.3	Gearbox Maintenance	19
5.02.4	Changing Bearings	19
5.02.5	Greasing Wheel Bearings	19
6	Trouble Shooting	20
7	Options	21
7.01	Crust Buster	21
7.02	Hydraulic Propeller Agitator	21
7.03	Vertical Deflector	21
7.04	2 Point Hitch Pump	21
8	Specifications	22
8.01	Mechanical Specifications	22
8.02	Tire Options	22
8.03	Wheel Bolt Torque	22
9	Index	23
10	Parts Book	23

SERIAL NUMBER LOCATION

Always give your dealer the serial number of your Liquid Manure Pump when ordering parts or requesting service or other information.

The serial number plate(s) is located where indicated. Please mark the number in the space provided for easy reference.

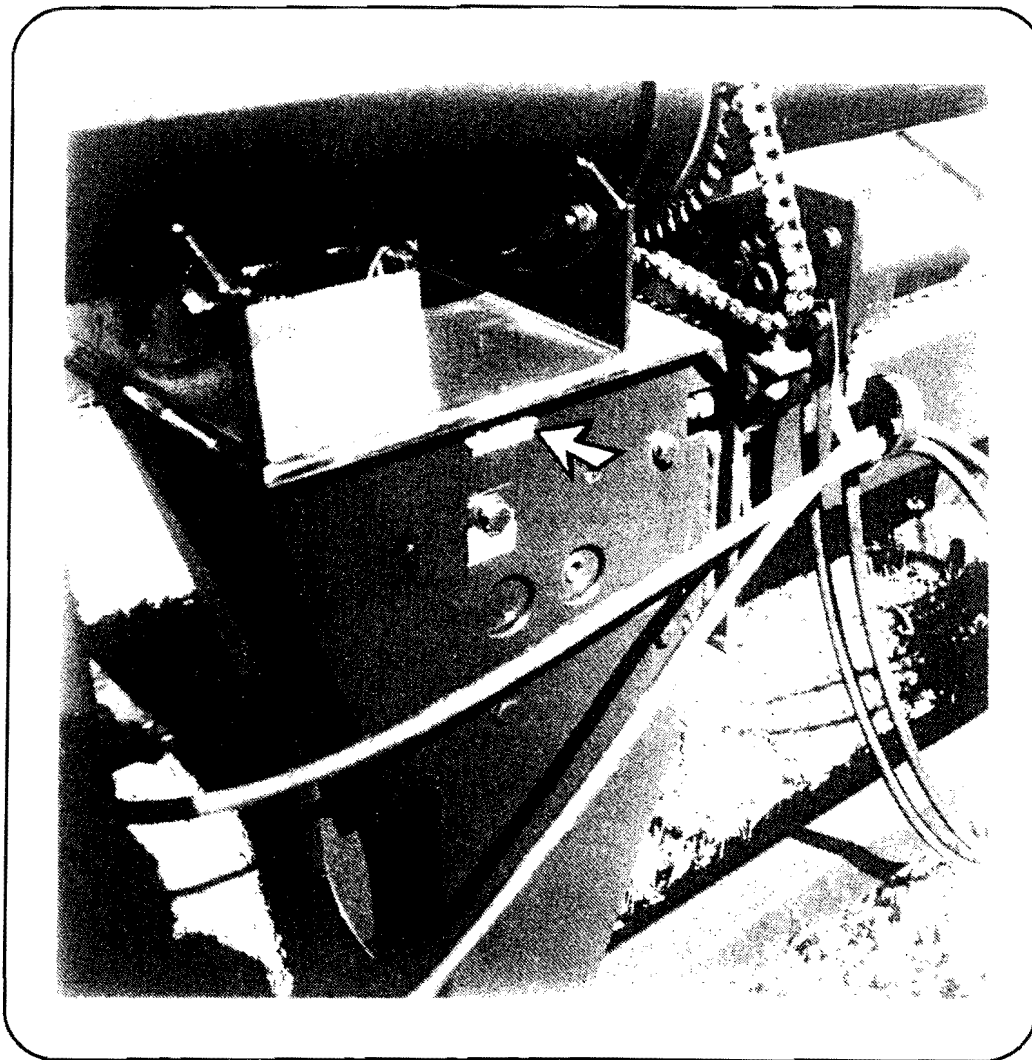

SERIAL NUMBER LOCATION

Model type _____

Serial number _____

Production year _____

1 INTRODUCTION

Congratulations on your choice of a Husky Liquid Manure Pump to compliment your farming operation. This equipment has been designed and manufactured to meet the needs of most discerning operators. The highest quality components are used throughout, and each step of Husky manufacturing is inspected under strict quality control.

Safe, efficient and trouble-free operation of your Husky Liquid Manure Pump requires that you and everyone else who will be operating or maintaining the machine read and understand all of the safety, operation, maintenance and trouble shooting information contained within this Operator's Manual.

Keep this manual handy for frequent reference and to pass on to new operators or owners. Call your Husky Dealer if you need assistance, information or additional copies of the manuals.

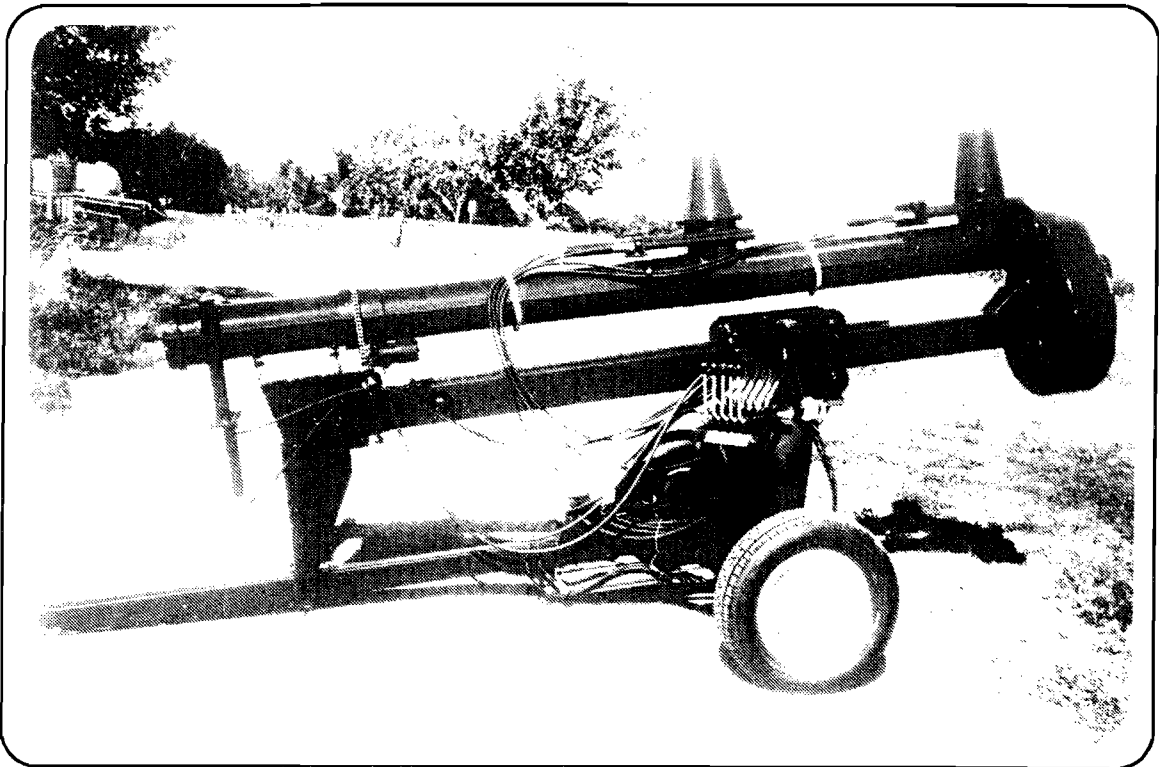

OPERATOR ORIENTATION

The directions left, right, front and rear, as mentioned throughout the manual, are as seen from the tractor driver's seat and facing in the direction of travel.

2 SAFETY

SAFETY ALERT SYMBOL

This Safety Alert symbol means
**ATTENTION! BECOME ALERT
YOUR SAFETY IS INVOLVED**

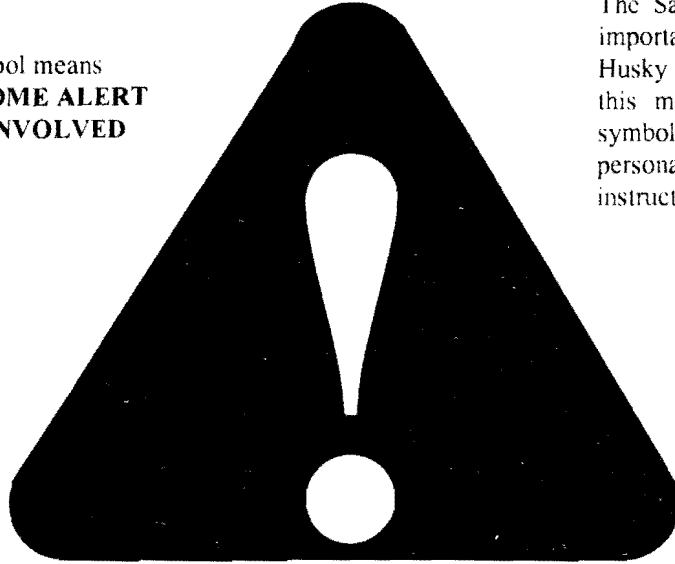

The Safety Alert symbol identifies important safety messages on the Husky Liquid Manure Pump and in this manual. When You see this symbol, be alert to the possibility of personal injury or death. Follow the instructions in the safety message.

Why is SAFETY important to you?

3 Big Reasons

Accidents Disable and Kill
Accidents Cost
Accidents Can Be Avoided

SIGNAL WORDS:

Note the use of the signal words **DANGER**, **WARNING** and **CAUTION** with the safety messages. The appropriate signal word for each message has been selected using the following guide-lines

DANGER - An immediate and specific hazard which **WILL** result in severe personal injury or death if the proper precautions are not taken.

WARNING - A specific hazard or unsafe practice which **COULD** result in severe personal injury or death if the proper precautions are not taken.

CAUTION - Unsafe practices which **COULD** result in personal injury if the proper practices are not taken, or as a reminder of good safety practices.

SAFETY

YOU are responsible for the SAFE operation and maintenance of your Husky Liquid Manure Pump. **YOU** must ensure that you and anyone else who is going to operate, maintain or work around the Husky Liquid Manure Pump be familiar with the operating and maintenance procedures and related **SAFETY** information contained in this manual. This manual will take you step-by-step through your working day and alerts you to all good safety practices that should be adhered to while operating this equipment.

Remember, **YOU** are the to safety. Good safety practices not only protect you but also the people around you. Make these practices a working part of your safety program. Be certain that **EVERYONE** operating this equipment is familiar with the recommended operating and maintenance procedures and follows all the safety precautions. Most accidents can be prevented. Do not risk injury or death by ignoring good safety practices.

Husky Liquid Manure Pump owners must give operating instructions to operators or employees before allowing them to operate the Liquid Manure Pump and at least annually thereafter per OSHA regulation 1928.57.

Husky Liquid Manure Pump owners must follow safety practices as recommended by the Agriculture Safety Associations across Canada .

The most important safety device on this equipment is a SAFE operator. It is the operator's responsibility to read and understand ALL Safety and Operating instructions in the manual and to follow these. All accidents can be avoided.

A person who has not read and understood all operating and safety instructions is not qualified to operate the machine. An untrained operator exposes themselves and bystanders to possible serious injury or death.

Do not modify the equipment in any way. Unauthorized modification may impair the function and/or safety and could affect the life of the equipment.

Think SAFETY! Work SAFELY!

2.01 GENERAL SAFETY

1. Read and understand the Operator's Manual and safety signs before operating, maintaining, adjusting or unplugging the husky liquid manure pump.

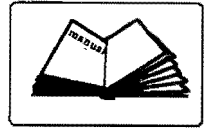

2. Have a first aid kit available for use should the need arise and know how to use it.

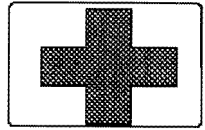

3. Have a fire extinguisher available for use should the need arise and know how to use it.



4. Install and properly secure all shields and guards before operating.

5. Do not allow riders on the machine or tractor.

6. Stop tractor engine, disengage PTO clutch, set park brake, remove ignition key and wait for all moving parts to stop before servicing, adjusting, repairing or unplugging.

7. Never enter manure storage facility without appropriate respiratory equipment and an independent oxygen supply.

8. Review safety related items with all operators annually

2.02 OPERATING SAFETY

1. Read and understand the Operator's Manual and all safety signs before operating, servicing, adjusting or unplugging.
2. Do not allow riders on the Husky Liquid Manure Pump or the tractor during operation, transport or filling.
3. Do not operate a PTO driven system unless the required shields are in place and secured.
4. Never wear loose fitting clothing, keep hands, feet, hair and clothing away from all moving and/or rotating parts, while working with machinery, use personal protective clothing and eye and ear protection as needed.
5. Stop tractor engine, disengage PTO clutch, set park brake, remove ignition key and wait for all moving parts to stop before servicing, adjusting, repairing or unplugging.
6. Before applying hydraulic pressure to the system, make sure everyone is clear and that all connections are tight and all components are in good repair.
7. Never enter Manure tank or manure storage facility without wearing appropriate breathing gear that carries an independent supply of oxygen.
8. Always use a tractor of sufficient size and weight to maintain vehicle stability during transport and during use.
9. Clean or install reflectors and SMV emblem before transporting and add extra lights for transporting during times of limited visibility.
10. Make sure parking brake on the tractor is set and block wheels so it cannot roll.
11. Make sure the PTO is not run on too great an angle it will cause vibration and could shear a pin in the PTO or it could cause the PTO to break and increase the danger of injury.
12. Review all safety instructions annually.

Think SAFETY! Work SAFELY!

2.03 MAINTENANCE SAFETY

1. Read and understand all the information contained in the Operator's Manual regarding maintenance, adjusting and operating the Husky Liquid Manure Pump.
2. Block the frame up securely and firmly if adjustments and maintenance to the Liquid Manure Pump require raising the wheel and tire assemblies off the ground.
3. Exercise extreme caution when working around or with high-pressure hydraulic systems. Depressurize the system when connecting or disconnecting the hose couplers.
4. Wear heavy gloves and eye protection when searching for suspected hydraulic leaks. A high-pressure concentrated stream of hydraulic fluid can pierce the skin. If such happens, seek immediate medical attention as infection and toxic reaction could develop.
5. Do not attempt any adjustment or maintenance to any system of the Liquid Manure Pump when the implement is in motion.
6. Be very careful and exercise extreme caution when working around or near a rotating PTO shaft.
7. Do not operate PTO system unless the rotating shield and all other guards are in place.
8. Never wear ill-fitting, baggy or frayed clothing and never have unkempt long hair when working around or on any of the drive system components.
9. Stop the engine, place all controls in neutral, remove the ignition key, set the park brake and wait for all moving parts to stop before servicing, adjusting, repairing or unplugging any system or component.
10. Never enter tank or manure storage facility without wearing appropriate breathing gear that carries an independent supply of oxygen. The buddy system is also a recommended procedure.

2.04 HYDRAULIC SAFETY

1. Make sure that all components in the hydraulic system are kept in good condition and are clean.

2. Replace any worn, cut, abraded, flattened or crimped hoses and metal lines.

3. Do not attempt any makeshift repairs to the hydraulic lines, fittings or hoses by using tape, clamps or cements. The hydraulic system operates under extremely high-pressure; 1600 to 3000 pounds per square inch. Such repairs will fail suddenly and create a hazardous and unsafe condition.

4. Wear proper hand and eye protection when searching for a high-pressure hydraulic leak. Use a piece of wood or cardboard as a backstop instead of hands to isolate and identify a leak.

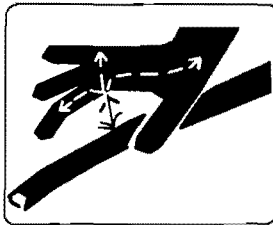

5. If injured by a concentrated high-pressure stream of hydraulic fluid, seek medical attention immediately. Serious infection or toxic reaction can develop from hydraulic fluid piercing the skin surface.

6. Before applying pressure to the system, make sure all components are tight and that lines, hoses and couplings are not damaged and kept in good repair.

7. Make sure all hydraulic hoses are not snagged on anything

2.05 TRANSPORT SAFETY

1. Make sure you are in compliance with all local regulations regarding transporting agricultural equipment on public roads and highways. Consult your local law enforcement agency for further information.

2. Ensure that the SMV (Slow Moving Vehicle) emblem and all reflectors and lights required by the local highways and transport authorities are in place and are clean and visible by overtaking and oncoming traffic.

3. Ensure that the Liquid Manure Pump is hitched positively and safely to the tractor drawbar. Use proper safety chain to secure a safe hitch hookup when transporting.

4. Transport according to local regulations covering maximum width, weight and length.

5. Do not exceed speed limits. Reduce speed on rough roads and surfaces.

6. Always use a tractor of sufficient size and weight to maintain vehicle stability during transport.

7. Always use hazard warning flashers on tractor when transporting unless prohibited by law.

Think SAFETY! Work SAFELY!

2.06 MANURE STORAGE FACILITY SAFETY

1. Never enter tank or manure storage facility without wearing appropriate breathing gear that carries an independent supply of oxygen .
2. Keep others, especially children, out of these structures.
3. Use special care when opening storage facilities to prevent yourself or others from falling in.
4. Stored manure gives off hydrogen sulfide gas. One breath can kill. Keep away. Keep others away.

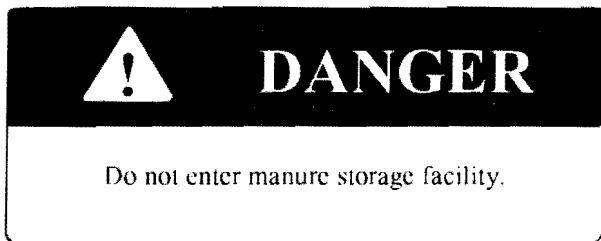

5. Do not enter storage facility without oxygen supplying equipment. The surface always crusts and looks solid. It is not. Stay away.
6. Set and adjust agitator before placing in pit. Never enter pit to unplug. Remove first.
7. Always have a ladder in storage tank as a means of getting out should you inadvertently fall in.

2.07 STORAGE SAFETY

1. Store the Liquid Manure Pump on a firm, level surface.
2. Store away from areas of human activity. Do not permit children to play on or around the stored Liquid Manure Pump.
3. Make sure the unit is sitting, or blocked up firmly and solid and will not tip or sink into a soft area.

2.08 TIRE SAFETY

1. Failure to follow proper procedures when mounting a tire on a wheel or rim can produce an explosion which may result in serious injury or death.
2. Do not attempt to mount a tire unless you have the proper equipment and experience to do the job.
3. Have a qualified tire dealer or repair service perform required tire maintenance.
4. Check wheel bolt torque daily.

2.09 SAFETY DECALS

1. Keep safety decals and signs clean and legible at all times.
2. Replace safety decals if destroyed, missing, painted over or unreadable.
3. If a section of the pump is replaced that carries a safety decal, apply a new decal immediately.
4. Safety decals or signs are available from your Dealer's Parts Department.

HOW TO INSTALL SAFETY DECALS:

- Be sure that the installation area is clean and dry.
- Decide on the exact position before you remove the backing paper.
- Remove the smallest portion of the split backing paper.
- Place the sign in position and slowly peel back the remaining paper, smoothing the sign as it is applied.

2.10 SIGN-OFF FORM

Husky Farm Equipment follows the general standards specified by the American Society of Agriculture Engineers (ASAE), the Occupational Safety and Health Administration (OSHA) and safety practices as recommended by the Agriculture Safety Associations across Canada. Anyone who will be operating and/or maintaining the Husky Liquid Manure Pump must read and clearly understand ALL Safety, Operating and Maintenance information presented in this manual.

Do not operate or allow anyone else to operate this equipment until such information has been reviewed. Annually review this information before the season start-up.

Make these periodic reviews of SAFETY and OPERATION a standard practice for all of your equipment. We feel that an untrained operator is unqualified to operate this machine.

A sign-off sheet is provided for your record keeping to show that all personnel who will be working with the equipment have read and understand the information in the Operator's Manual and have been instructed in the operation of the equipment.

EMPLOYEE SIGN-OFF FORM

DATE	EMPLOYEES SIGNATURE	EMPLOYERS SIGNATURE

3 SAFETY DECAL LOCATIONS

The types of decals on the equipment are shown in the illustration below. Good safety requires that you familiarize yourself with the various Safety Decals, the type of warning and the area, or particular function related to that area, that requires your SAFETY AWARENESS.

Think SAFETY! Work SAFELY!

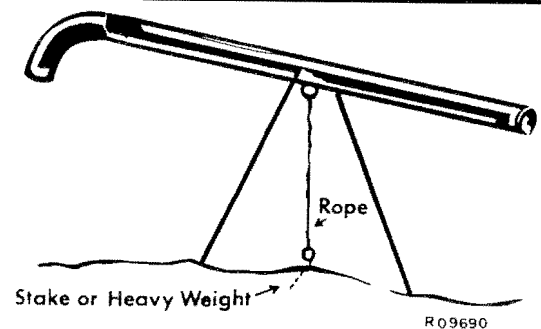
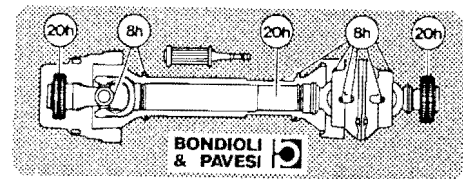

REMEMBER - If safety decals have been damaged, removed, become illegible or parts replaced without decals, new decals must be applied. New decals are available from your authorized dealer.

4 OPERATION

4.01 TO THE NEW OPERATOR OR OWNER

Husky Farm Equipment's Liquid Manure Pumps are designed to efficiently agitate and pump liquid manure from the storage facility to the hauling tank, transferring to alternative storage or to feed a high pressure irrigation pump for irrigating the manure. Many of the features incorporated into this machine are the result of suggestions made by customers like you. Read this manual carefully to learn how to operate the machine safely and how to set it to provide maximum efficiency. The manual will take you step-by-step through your working day. By following the operating instructions in conjunction with a good maintenance program, your Liquid Manure Pump will provide many years of trouble-free service.

General Information About the Husky Liquid Manure H5000/H6000 Pump

Husky Farm Equipment Limited designs and manufactures all of its products so they can be operated safely. However the responsibility for safe operation rests with those who use and maintain these products.

The Husky Liquid Manure Pump should be operated only by those who have been trained to do so, and who have read these operating instructions and operating manual. Failure to follow the instructions, procedures and safety precautions in this manual may increase the possibility of an accident or injury.

The Husky H5000 Liquid Manure Pump is designed to be driven with a farm tractor with a 540 RPM PTO (1:1.35 ratio), or the gear box can be turned over to operate at 1000 RPM (1.35:1 ratio). The Husky H6000 Pump is designed just for 1000 RPM (1:1 ratio). If run at higher RPM's damage to gear box and drive train could result.

The Husky Liquid Manure Pump comes in different lengths to suit different pit depths, make sure the pump you are using is matched with the pit so that PTO runs reasonably straight. If PTO is run on too great an angle it will cause vibration and could shear a pin in the PTO or it could cause the PTO to break and increase the danger of injury, or it would wear the bearings in the gear box prematurely.

The H5000 Liquid Manure Pump takes between 70 and 100 HP tractor to operate efficiently. The H6000 Liquid Manure Pump takes 150 HP. A smaller tractor will operate the Liquid Manure Pump satisfactorily to fill tank or transfer but will not come up to full RPM, putting a larger tractor on the pump will not damage the pump providing it is run at proper speed.

4.02 HOW THE MACHINE WORKS

The Husky Liquid Manure Pump uses a P.T.O. driven impeller or fan assembly to carry the manure in a pipe from the pit or storage area to a manure spreader, remote storage facility, truck or container of some description. A pipe attached to the top of the pump called a discharge pipe carries the manure.

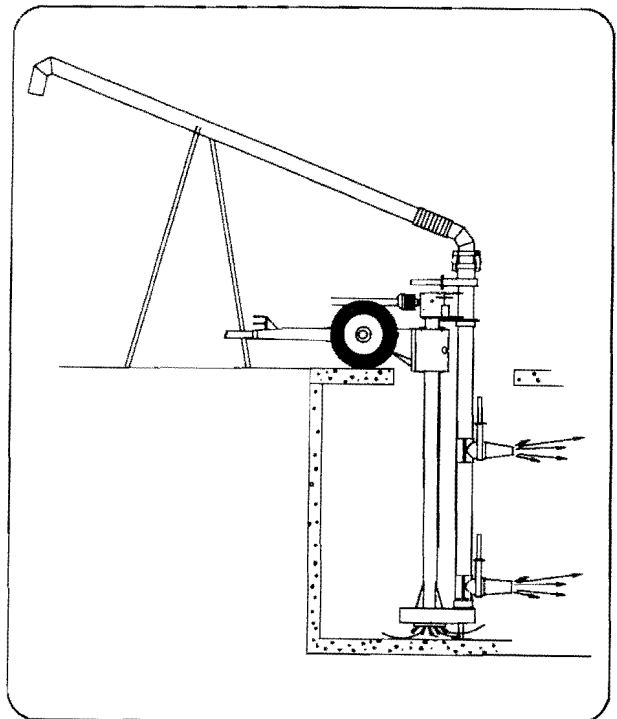

FIG. 1 PRINCIPALS OF OPERATION

Optional equipment includes

1. Hydraulic or manual deflector / crustbuster
2. Electric drive
3. Hydraulic propeller agitating fan
4. Two point hitch

4.03 BREAK-IN FOR H5000/H6000

Although there are no operational restrictions on the pump when it is new, there are some mechanical checks that must be done to insure long term integrity of the unit. When using the pump for the first time, follow this procedure:

A. Before Using

1. Lubricate all grease points.
2. Check level of oil in the gearbox to be 1/2 full
3. Retorque wheel bolts to the values listed in Maintenance section.

B. After 40 and 100 miles on the road or 2 hours and 5 hours of use:

1. Retorque wheel bolts to the specified values listed in Maintenance section.
2. Check all hardware. Tighten as required.
3. Lubricate all grease points.

C. Then go to the service schedule as outlined in the maintenance schedule.

4.03.1 TOWING

1. When towing the Husky Liquid Manure Pump always put a safety pin in the draw bolt and use safety chains as required by the Department of Transport.
2. At high speed the pump may weave on the road, never travel at excessive speed.
3. Always check wheel bolts and bearings and tires before and during towing.
4. Tie a red flag, or red light at night on the end of the pump while towing or as required by the Department of Transport.
5. Use Slow Moving Vehicle sign if towing less than 25 M.P.H. or as required by the Department of Transport.

4.04 PRE-OPERATION CHECKLIST

Efficient and safe operation of the Husky Liquid Manure Pump requires that each operator reads and understands the operating procedures and all related safety precautions outline in this section. A pre-operation checklist is provided for the operator. It is important for both personal safety and maintaining the good mechanical condition of the Pump that this checklist be followed.

1. Lubricate the machine per the schedule outlined in the "Maintenance Section".
2. Use only a tractor of adequate power and weight to operate the Pump.
3. Ensure that the machine is properly attached to the tractor using a drawbar pin and a retainer such as a pin made for draw bolts is installed.
4. Ensure that the PTO driveline is securely attached on both ends and that there is proper overlap in length so that the PTO won't come apart or jam up.
5. Check that PTO shields are in place and that it can rotate freely and telescope freely. Secure the PTO shield safety chain (if supplied) to the PTO guards.
6. When using the hydraulic system for the pump:
 - A. Inspect all hydraulic lines, hoses, fittings and connectors. Tighten any loose fittings and replace any damaged components.
 - B. Use a clean cloth to wipe any accumulated dirt from the couplers before connecting to the tractor's hydraulic system.
 - C. Be sure the hydraulic reservoir in the tractor is filled to the required specification.
 - D. Be sure the tractor hydraulic system specifications match the requirements of the motors & cylinders.
7. Check the tires and ensure that they are inflated to the specified pressure (See Specifications Section).
8. Check the wheel bolt torques. Be sure to retorque as required to the specified level.
9. Be sure that any lights, reflectors or SMV signs if installed are clean.

4.05 EQUIPMENT MATCHING

Special attention must be given to selecting a tractor with sufficient power to safely maneuver and run the pump.

As a general guideline, Table 1 lists the minimum horsepower requirements for the tractor when the unit is in normal conditions.

TABLE 1 TRACTOR HORSEPOWER REQUIREMENTS

SIZE OF PUMP	APPROX. LITRES	RECOMMENDED TRACTOR HORSEPOWER
3" electric pump	1400 LPM (300 GPM)	5 HP electric motor
4" electric pump	2000 LPM (450 Imp GPM)	10 HP electric motor
6" K31 Pump	14000 LP (3000 Imp GPM)	60 to 70 Tractor HP
8" H5000 pump	23000 LPM (5000 Imp GPM)	90 to 100 Tractor HP
8" H6000 pump	31000 LPM (7000 Imp GPM)	150 to 160 Tractor HP
8" PL290 lagoon pump	31000 LPM (7000 Imp GPM)	150 to 160 Tractor HP
Propeller Agitator	100000 LPM (22000 Imp GPM)	100 to 150 Tractor HP

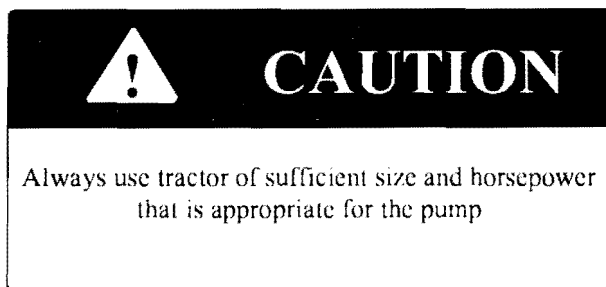

HYDRAULIC SYSTEM:

If using a hydraulic system, make sure that the system is set to supply the specified volume and pressure for the pump. If you have any questions about the type of hydraulic system in the tractor or its output, consult the tractor Operator's Manual. The motor requires 20 GPM (75 Litre/min) flow at 2000 PSI.

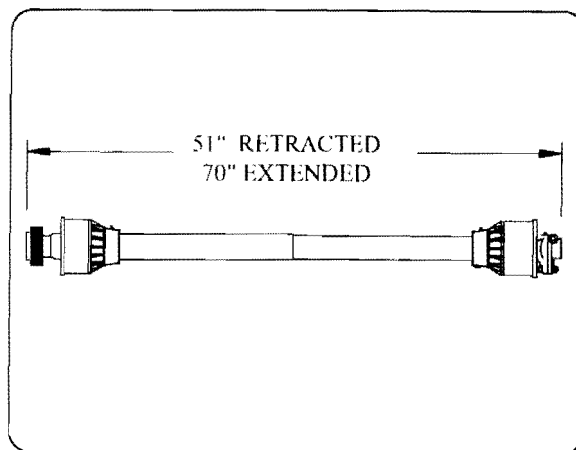

FIG. 2 DRIVELINE DIMENSION

If the dimension varies by more than 3 inches (76 mm) adjust the tractor drawbar. (Refer to tractor manual for details.)

4.06 INSTALLATION OF THE H5000/H6000 PUMP

4.06.1 TRAILER MODEL

1. There are 2 hitches on the tongue of the pump; the hitch at the end of the tongue is for transportation, and the hitch sliding on the tongue is to hook on to the tractor for operating the pump.
2. When hooking up hydraulics follow these steps
 - A. Inspect all hydraulic lines, hoses, fittings and connectors. Tighten any loose fittings and replace any damaged components.
 - B. Use a clean cloth to wipe any accumulated dirt from the couplers before connecting to the tractor's hydraulic system.
 - C. Be sure the hydraulic reservoir in the tractor is filled to the required specification.
 - D. Be sure the tractor hydraulic system specifications match the requirements of the pump.
3. Use the hitch that slides on the tongue for backing up to the edge of the pit, hook up the hydraulic hoses to the tractor making sure they are fully engaged, unlatch the brackets that fastens the tongue to the gearbox bracket, pull the "T" pin handle on the trailer roller assembly to allow the pump to slide. Run the hydraulics in and out several times to make sure that air is eliminated from the hydraulic lines and motor. Tilt the pump into the pit and lower the pump until it reaches the bottom of the pit using the controls on the valve bank and in the tractor. If the tractor has only one hydraulic bank it is possible to tip the pump into a vertical position first and then switch hoses to lower the pump into the pit. It is best if the pump rests on the floor of the pit but if it does not reach it will do no harm except the pump may push sideways when agitation takes place.
4. After the pump is in the pit ready for pumping the hitch must be unhitched and backed over the tongue and hooked up to the back tongue. It will be necessary to block or fasten the pump until it is re-hitched; otherwise it could roll back and fall into an open top pit. This can usually be done by driving a stake in behind the pump axle or into the crotch of the tongue, or chain to wall or post.
5. Block wheels of tractor when in place.

6. Hook up the PTO and the discharge pipe by following the instructions in the Attaching Accessories section next in this manual.

4.06.2 2 POINT HITCH

1. The two point hitch model is mounted onto the hitch arms of the tractor, as the arms are lifted the pump is positioned straight out behind the tractor. The pump is equipped with a hydraulic cylinder to tip it into the pit. Follow hydraulic hookup steps from trailer installation section 4.06.1 and hook up the hydraulic hoses to the tractor hydraulic system. Work the cylinder in and out a few times to make sure that air is eliminated from the hydraulic lines.
2. Always make sure the tractor is heavy enough to support the pump so the tractor will not lift up on the front end. Back over the wall of the pit and using the hydraulic cylinder tip the pump into the pit, after the pump is vertical lower the hitch arms until the pump rests on the bottom of the pit. Always lock parking brakes firmly so tractor will not roll back into pit.
3. Block wheels of tractor when in place.
4. Hook up the PTO and the discharge pipe by following the instructions in the Attaching Accessories section next in this manual.
5. When removing the pump from the pit raise the two point hitch arms and tilt the pump up with the hydraulic cylinder. Do not catch the agitation tees on the concrete as you are lifting the pump out. Drive away from the pit being very careful that you do not let the clutch out too quickly or the tractor may raise on the front end as the pump is quite heavy.

4.07 ATTACHING ACCESSORIES

1. After the pump is in place using the installation guideline section 4.06. Hook up the PTO to the pump and to the tractor, make sure the quick disconnect pin is latched properly on both ends, if equipped with safety collar check that pin has returned to running position. Check the shield on the PTO to make sure it is turning freely and in proper working condition. Fasten PTO safety chain to the guard on the Husky Liquid Manure Pump and tractor if equipped. Never operate a machine unless the PTO shield is working properly.
2. Check to make sure the rubber gasket is in place in the top of the pump, then install the discharge pipe and latch tightly, raise the pipe up to the level required to clear the top of the manure spreader then place the bipod legs into each side of the pipe to support it at the proper level. Solid footing is needed for the legs. Then put in safety pin supplied to hold legs into discharge pipe. Install the chain provided between the legs so the legs cannot slip out allowing the pipe to come down.
3. Install an anchor chain onto the discharge pipe so it cannot lift up before pumping. The force of liquid coming out of the pipe will lift the pipe into the air which could cause damage or injury as it comes back down. The anchor could be heavy weights, stakes driven into the ground or a concrete block. The H5000/H6000 pipe would require approx. 600 lbs. (270 kg) to hold it down, make sure the rope or chain used is tight so the pipe cannot lift high enough to unlatch the bipod legs. Make sure the safety pins are installed in the hooks of the bipod legs so they cannot come unhooked. Never leave discharge pipe full of manure as it could freeze and split it.

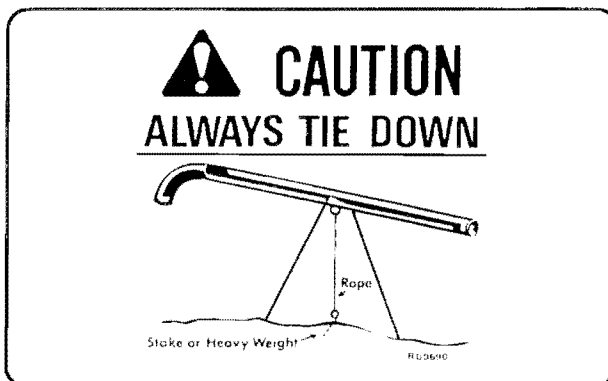

FIG 3. TIE PIPE DOWN

4.08 OPERATION OF THE H5000/H6000 PUMP

1. You are now ready to start the pump - before starting make sure the top valve is closed. This can be done by using the correct lever on the control bank. Open one of the agitator valves and start the pump slowly until you are satisfied everything is functioning properly. You will know whether you need to use the top agitator or the bottom one, if you have a lot of crust on the manure you will use the top one, otherwise use the bottom one.
2. There is a manual or hydraulic vertical deflector which is optional that can be used to deflect the stream up or down to break through the crust.
3. The agitator can be rotated CW or CCW by using the hydraulics to rotate the spouts.
4. After you have agitated the pit by breaking up the solids then you can start hauling. It may not be necessary to have the pit completely agitated before hauling as you will continue to agitate between loads as you haul the manure to the field.
5. When you are ready to fill the spreader (follow the spreader operation manual when operating the spreader), slow the tractor down or turn the P.T.O. off. Caution should be taken if the tractor is left at full R.P.M. Open the top valve by using the hydraulic lever provided.
6. Usually the pump creates foam as it is loading the manure spreader and when the spreader is nearly full the foam will rise above the fill hole so you can tell when the tank is full. If you want the tank right full you may have to slow the stream down until the foam subsides.
7. It is usually not necessary to close the agitator valve when pumping, as it will pump fast enough with one agitator valve open. If the manure is very thick or you want to pump very fast then you would have to close the agitator valves. It will not damage anything if all three valves should accidentally be closed while the pump is running..

4.09 REMOVING LIQUID MANURE PUMP

1. Drain the manure from the discharge pipe, then remove the pipe and bipod legs from the pump
2. Remove the P.T.O. from the pump
3. When removing the pump from the pit always hook onto the front hitch of the tongue. Caution should be taken when tilting the pump forward that it cannot hit the tractor cab or operator and cause damage.
4. Lift the pump with the hydraulic motor, tilt the pump up with the hydraulic cylinder, careful not to catch the agitation tees on the concrete as you are lifting the pump out. Drive away from the pit slowly to make sure all parts of the pump are clear
5. When lifting out the 2 point hitch pump do not let the clutch out too fast or the tractor may raise on the front end as the pump is quite heavy

4.10 CLEAN-UP

At the end of cleaning your manure facility, follow this procedure to clean the machine:

1. Wash the outside of the Husky Liquid Manure Pump with a hose or pressure washer.
2. If the temperatures are below freezing, be sure the water has a chance to drain so pump will not freeze.
3. All Manure pumps are subject to the effects of acid in the manure, if the pump is removed from the pit it should be stored away from the pit area preferably inside. It is good practice to have a small canister sprayer and to spray light oil both before and after using.
4. When cleaning at the end of the season, a more thorough cleaning and inspection is required (refer to Section 4.11)

4.11 STORAGE

4.11.1 PLACING IN STORAGE

After the season's use, inspect all systems of the Husky Liquid Manure Pump. Repair or replace any worn or damaged components to prevent any down time at the beginning of the next season. Since the machine works with manure, it is necessary to thoroughly wash the unit to prevent manure acids from working on the components while in storage. All manure, debris and residue should be removed. It is good practice to have a small canister sprayer and to spray light oil both before and after using.

1. Inspect all hydraulic hoses, lines, couplers and fittings. Tighten any loose fittings. Replace any hose that is badly cut, nicked, abraded or is separating from the crimped end of the fitting.
2. Lubricate all grease fittings (see Maintenance Section). Make sure that all grease cavities have been filled with grease to remove any water residue from the washing.
3. Check the bearings according to the maintenance section
4. Touch up all paint nicks and scratches to prevent rusting.
5. Select an area that is dry, level and free of debris for storage.
6. Refrain from letting children play on or around the Husky Liquid Manure Pump.

4.11.2 REMOVING FROM STORAGE

Before starting to use the machine, the owner should do a thorough inspection and servicing. Follow this procedure:

1. Lubricate all grease fittings to remove any condensation that accumulated during the storage period.
2. Torque all wheel bolts and check tire pressure to the specified values.
3. Check the level of oil in the gearbox to be 1/2 full.

5 SERVICE AND MAINTENANCE

MAINTENANCE
SAFETY

1. Stop tractor engine, place all controls in neutral, set park brake, remove ignition key and wait for all moving parts to stop before servicing, repairing, adjusting or unplugging.
2. Be careful when working around a high pressure hydraulic system. Wear the proper eye and hand protection when searching for leaks. Use a piece of wood or cardboard as a backdrop when searching for leaks.
3. Seek immediate medical attention if hydraulic fluid pierces the skin as toxic reaction and infection could develop.
4. Keep hands, feet, hair and clothing away from all moving or rotating parts.
5. Make sure that all shields and guards are in place before operating.
6. Clear the area of bystanders, especially children, when carrying out any maintenance or making adjustments.
7. Always securely support the frame with stands or large blocks when removing a tire or working under the machine.
8. Never enter the tank without wearing appropriate breathing equipment that carries an independent supply of oxygen. Keep others out of the tank.

5.01 SERVICE

5.01.1 FLUIDS AND LUBRICANTS

1. Grease

Use an SAE multi-purpose high temperature grease with extreme pressure (EP) performance and containing at least 1.5% molybdenum disulfide. Also acceptable is an SAE multi-purpose lithium base grease.

2. Wheel Bearing Grease

Use an Esso EP2 or equivalent bearing grease at all times.

3. Gear Box Oil

Use a SAE 90 EP gear box oil. The EP (Extreme Pressure) additive gives better life in the gear box.

4. Storing Lubricants

Your machine can operate at top efficiency only if clean lubricants are used. Use clean containers to handle all lubricants. Store them, properly labelled and sealed, in an area protected from dust, moisture and other contaminants.

5.01.2 GREASING

Refer to section 5.01.1 for recommended grease. Use the Maintenance Checklist provided to keep a record of all scheduled maintenance.

1. Use only a hand-held grease gun for all greasing. Air powered greasing systems can damage the seals on bearings and lead to early bearing failure.

2. Wipe grease fitting with a clean cloth before greasing, to avoid injecting dirt and grit.

3. Replace and repair broken fittings immediately.

4. If fittings will not take grease, remove and clean thoroughly. Also clean the lubricant passageway. Replace with a new fitting if necessary.

5. Grease all grease fittings daily when in use.

5.01.3 GEARBOX

Refer to section 5.01.1 for recommended Oil. Use the Maintenance Checklist provided to keep a record of all scheduled maintenance.

1. Do not fill the gear box over 1/2 full as this will result in overheating
2. Oil level should be checked daily when in use.
3. There is a vent plug in the side of the box to relieve the pressure as the oil warms up and expands. It is possible that some of the oil may push out through the plug when it is used the first time
4. It is normal for the box to run quite warm when working, if it should get very hot check the oil immediately and stop until it cools down

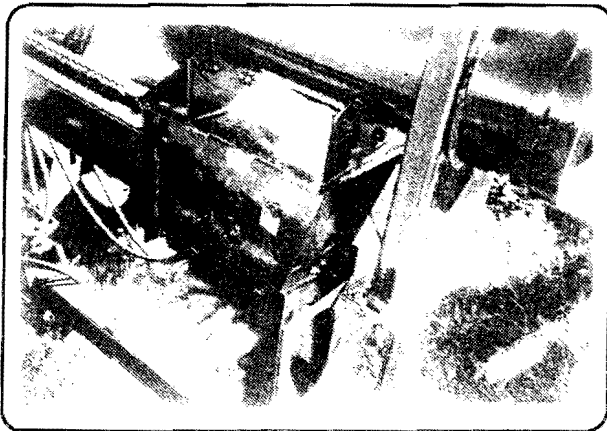

FIG. 4 GEARBOX

5.01.4 BEARINGS

1. The bearing on the bottom of the H5000/H6000 liquid manure pump is called a marine bearing and it is lubricated with the manure itself, this bearing needs no attention. When the pump is out of the pit and in transport position you can check the bearing wear by lifting on the fan at the bottom, if the fan moves over 1/2 "/>12.7mm it is time to change the bearing. (See changing the bearing in section 5.02.4 of this manual).
2. The bearing in the centre of the pump is an oil impregnated wooden block, it does not usually need replacing as it just keeps the shaft from whipping at high speeds. If the bearing is worn 1/2 "/>12.7mm it is time to change the bearing. (See changing the bearing in section 5.02.4 of this manual)

5.01.5 SERVICING INTERVALS

8 HOURS OR DAILY

1. Grease PTO Knuckles
2. Grease PTO Drive Knuckle below Gearbox
3. Grease PTO Shield.
4. Check Gear Box Oil Daily.

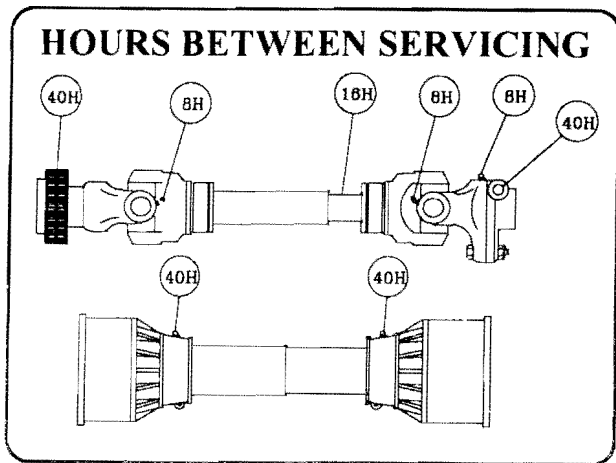

FIG. 5 PTO DRIVELINE SERVICING

ANNUALLY

1. Pull PTO apart grease telescope.
2. Grease PTO Shield.
3. Change Oil in Gearbox

If the Husky H5000/H6000 pump is used properly it should give many years of service. When worn parts are needed always call your dealer or the factory and get original parts.

5.01.6 SERVICING RECORD

See Lubrication and Maintenance sections for details of service. Copy this page to continue record.

ACTION CODE: ✓ CHECK C CHANGE CL CLEAN
 L LUBRICATE R REPLACE

HOURS SERVICED BY MAINTENANCE																			
8 HOURS																			
L PTO Driveline																			
L Driveshaft Knuckle																			
✓ Oil In Gearbox																			
20 HOURS																			
L PTO Driveline																			
L Driveshaft Knuckle																			
✓ Oil In Gearbox																			
40 HOURS																			
L PTO Driveline																			
L Driveshaft Knuckle																			
✓ Oil In Gearbox																			
80 HOURS OR ANNUALLY																			
L Wheel Bearings																			
CL Machine																			
✓ Bearings on Shaft																			
C Oil In Gearbox																			
750 HOURS OR ANNUALLY																			
C Oil In Gearbox																			
✓ Bearings on Shaft																			

5.02 MAINTENANCE

The efficient and safe operation of your Husky H5000/H6000 Liquid Manure Pump will depend to a great degree on your diligence in following the maintenance and adjustment procedures outlined in this section. If you follow these recommendations, your Pump should work to its maximum potential.

5.02.1 PTO SAFETY SHIELD MAINTENANCE

It is important that the shield components rotate freely over the PTO shaft. Lubricating both the shield bearings and also periodic cleaning will ensure safe operation of the rotating shield. To disassemble, clean and lubricate the shield, follow this procedure:

A. Press down the collar bearing catches with a screw driver to release the cone. Pull the cone towards the tube to remove it.

B. Spread the collar bearing and remove from the tube. Clean collar and the yoke bearing groove. After cleaning thoroughly, apply a good coat of grease to the bearing groove.

C. Fit the collar bearing into the groove and the tube ensuring that the collar catches are centered over the matching holes. The tube and bearing must rotate freely in the bearing groove.

D. Fasten the cone by lining up the cone grease fitting over the grease filling hole on the collar bearing. Make sure that all catches are fastened and that the shield turns freely over the shaft.

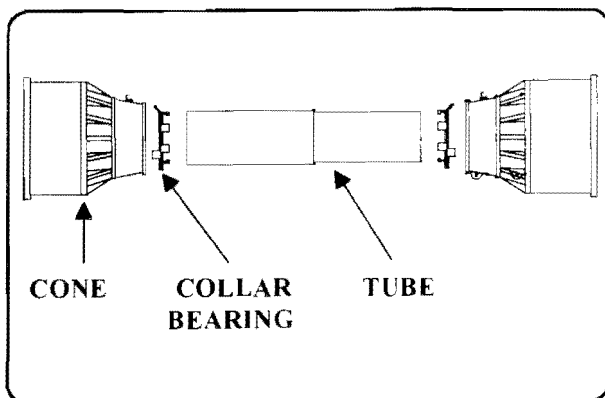

FIG. 6 DRIVELINE SHIELD COMPONENTS

5.02.2 PTO DRIVELINE SHEAR PIN

The PTO driveline is equipped with a shear pin to prevent damage to the mechanical drive should an object jam in the fan.

Follow this procedure when replacing the shear pin:

1. Stop tractor engine, place all controls in neutral, set parking brake, remove ignition key and wait for all moving parts to stop before dismounting.
2. Remove the ends of the shear bolt from each part of the yoke. It may be necessary to tap out the bolts with a punch if the end is distorted.
3. What to check for on the brass bearing and thrust washer type of shear flange assembly. Check that the brass bearing is not worn. Check that the thrust washer is in place and not worn or missing. Check the snap ring that it is correctly seated in the groove.
4. What to check for on the ball bearing shear flange assembly. Check that all the balls are in the cavity. Ensure that the grease fitting is in place and tight to hold all the balls in the proper location. If the shear flange was allowed to rotate several times, then the ball grooves on the inner and outer parts should be checked for wear or fracture.
5. Line up the bolt hole and install the shear bolt recommended by the manufacture.
6. Tighten the shear bolt securely in position.
7. Determine the cause of the bolt shearing. Remove the cause before using the machine again.

CAUTION

Use only the Grade of bolts to replace the shear pin that the manufacturer recommends. This bolt is designed to shear at a specific load to protect the system. Other bolts will not give the desired protection.

5.02.3 GEARBOX MAINTENANCE

1. Keep the vent plug clean at all times
2. Change the oil at regularly scheduled times as per section 5.01.6 of this manual.
3. Remove the gearbox from the pump.
4. Drain all the old oil from the gearbox and dispose of in a regulated fashion NOTE: Always drain oil at operating temperature
5. Monitor the oil for metal fragments or filings to check for premature wear.
6. Rinse clean the inside of the gearbox with a solvent cleaner.
7. Replace with new oil as per 5.01.1 of this manual
8. Reinstall gearbox

5.02.4 CHANGING BEARINGS

During the life of the Husky Liquid Manure Pump the bearings may become worn and need to be replaced. Proceed in this manner:

1. Stop tractor engine, place all controls in neutral, set parking brake, remove ignition key and wait for all moving parts to stop before adjusting or repairing the machine.
2. Remove the implement and PTO assembly and lay it to the side.
3. Remove cover plate and foot assembly.
4. Inspect inside housing for any wear.
5. Remove drive shaft universal yoke from gearbox
6. Unscrew bolts holding middle wood block (blocks) in place. Unscrew bolt holding bottom marine bearing in place.
7. Pull the complete shaft from the pump, being careful not to bend it.
8. The bearing can then be removed from the shaft by taking the universal off the shaft.

5.02.5 GREASING WHEEL BEARINGS

Follow this procedure when greasing the wheel bearings:

1. Be sure the pump is on flat ground.
2. Jack up the axle assembly and place stands or blocks under the frame.
3. Remove the hub cap, cotter pin, nut & hub to expose the bearings.
4. Re-grease the bearings. Use only ESSO EP2 or equivalent grease on these bearings.
5. If the grease appears to be dirty and contaminated, wash the bearings, axle and cavity using a good solvent.
6. Liberally apply grease to all the components keeping them free from any dirt.
7. Install the hub on the shaft and secure in position with the nut, cotter pin & hub cap.
8. Remove blocks or stands from under the frame.
9. Lower to the ground.

6 TROUBLE SHOOTING

The Husky Farm Equipment H5000/H6000 Liquid Manure Pump is a simple transportable pump that is used to transfer liquids. It is a reliable system that requires minimum maintenance.

In the following section, we have listed many of the problems, causes and solutions to the problems you may encounter. If you encounter a problem that is difficult, after having read through this trouble shooting section, please call your local Husky dealer or call the factory direct. Ask for service and have serial number of your Pump ready.

PROBLEM	CAUSE	SOLUTION
Pump fan does not run.	Broken shear bolt.	Replace shear pin. Check for cause of failure & remove cause.
	Broken shaft	Replace with new part
	Broken gear box	Repair at your local dealer
Manure won't pump.	Slurry too thick.	Add water & agitate.
	Lifting too far.	Decrease load out position
	Fan or pipe plugged.	Unplug.
Fan rubbing on bottom of housing	Knuckle is disconnected from gearbox	Connect knuckle back to gearbox
Gearbox overheated.	Overfilled gearbox	Drain some oil
	No oil	Add some oil.
Gearbox noisy	Broken gear	Replace gear
	No oil	Add some oil.
Manure coming to top of driveshaft tube	Bearings are worn if there is excessive flow	Replace bearings
Manure leaking from swivel joint or discharge pipe connection	Rubber gasket needs replacing	Replace with a new factory part
Top valve will not work	Jammed with manure	Dismantle and clean
	Hydraulic cylinder not working	Repair hydraulic cylinder
Agitator valves will not work	Hydraulic cylinder not working	Repair hydraulic cylinder
	Cone plugged	Remove pump and unplug

7 OPTIONS

7.01 CRUST BUSTER

Is available to connect to the top of the pump in place of the discharge pipe. It is a vertical agitator that rotates manually. The hydraulics are run from tractor or the pump. Call factory for details.

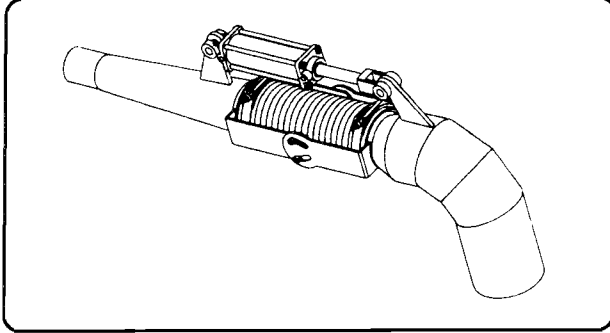

7.03 VERTICAL DEFLECTOR

Is available to connect to the top agitator. Hydraulic option. The assembly bolts on to a flange on the top valve. This assembly may be moved to the bottom if needed. Your hole opening needs to be 30 inches larger. Call factory for details.

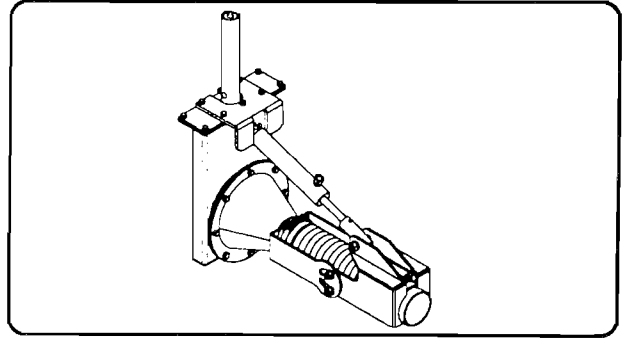

7.02 HYDRAULIC PROPELLER AGITATOR

Is available to connect to the Drive shaft tube of the pump. The hydraulics are run from tractor. The assembly clamps around the pipe. Call factory for details.

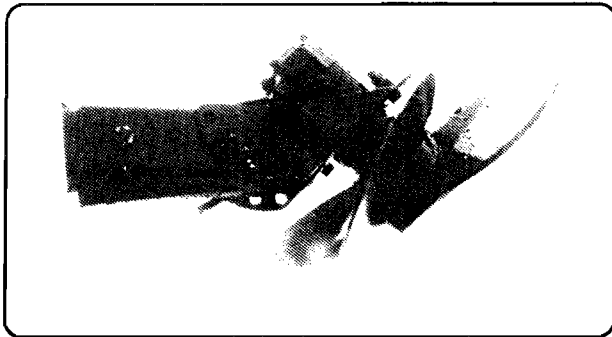

7.04 2 POINT HITCH PUMP

Available in all the standard sizes

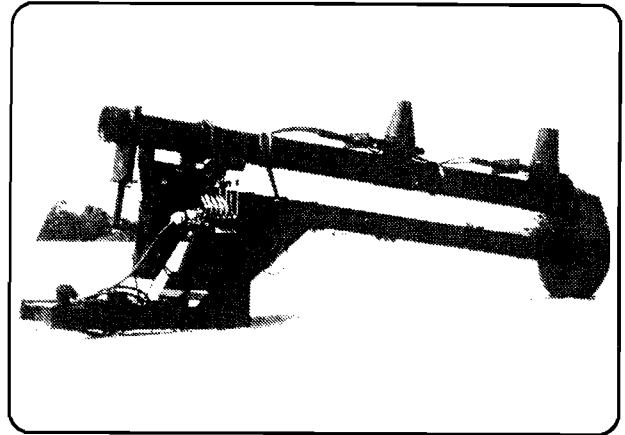

8 SPECIFICATIONS

8.01 MECHANICAL

All capacities are approximate and will vary with material consistency.

MODEL	3" ELEC.	4" ELEC.	K31	H5000	H6000	LAGOON	PROPELLER
LITRES PER MINUTE	1800	2700	14000	23000	27000	27000	100000
U.S. GALLON/MIN	480	720	3600	6000	7000	7000	24000
IMP.GALLON/MIN	400	600	3000	5000	6000	6000	22000
LENGTH FEET	4' - 12'	4' - 12'	8' - 14'	8' - 14'	8' - 14'	30 - 40 - 50	20' - 24'
DIAMETER	3"	4"	6"	8"	8"	8"	N/A
SHIPPING WEIGHT	90 KG	105 KG	544 KG	721 KG	721 KG	1710 KG	180 KG
H.P. REQUIRED	5-7 1/2	10	70	100	150	150	100
HOLE SIZE	15" X 21"	15" X 21"	24" X 32"	32" X 40"	32" X 40"	OPEN	32" X 60"
FAN DIAMETER	9"	9"	17.5"	17.5"	17.5"	17.5"	21" - 26" - 29"
INLET DIAMETER	5.5"	5.5"	12"	12"	12"	12"	N/A
NUMBER OF BLADES	3	3	4	4	4	4	3
HOUSING DIMENSION	14" X 23"	15" X 25"	24" X 30"	23" X 32"	23" X 32"	23" X 29"	N/A
OVERALL LENGTH	+ 58"	+ 58"	+ 50"	+ 55"	+ 55"	+ 0"	+ 6"
OVERALL WIDTH	42"	42"	69"	69"	69"	102"	38"
OVERALL HEIGHT	30"	30"	60"	64"	64"	116"	52"
TIRE SIZE	N/A	N/A	20570R/15	20570R/15	20570R/15	25570R/15	OPT.

8.02 TIRE OPTIONS

TIRE SIZE	TIRE TYPE	P.S.I.	KPA
4.80 X 4 X 8	HIGH SPEED TIRE	60	590
5.90 X 15	IMPLEMENT TIRE	35	240
20570R/15	AGRI - MAC	35	240
11L X 15	IMPLEMENT TIRE	35	240
25570R/15	AGRI - MAC	35	240
16.5L X 16.1	IMPLEMENT TIRE	35	240
18 X 22.5	USED TRUCK TIRE	65	448

8.03 WHEEL BOLT TORQUE

WHEEL BOLT SIZE	TORQUE FT. LBS		KG - METER	
	DRY	OILED	DRY	OILED
9/16 - 18 NF	120	90	16.5	12.44
5/8 - 18 NF	180	130	24.88	17.97
3/4 -18 NF	300	220	41.48	30.42

	PAGE		PAGE
		A	
Attaching Accessories	13		
		B	
Break - In	10		
Bearings Servicing	16		
		C	
Clean-Up	14		
Changing Bearings	19		
Crust Buster	21		
		D	
Driveline Dimensions	11		
Driveline Shield Components	18		
		E	
Equipment Matching	11		
Employee Sign-Off Form	07		
		F	
Fluids and Lubricants	15		
		G	
Gearbox Maintenance	19		
Gearbox Servicing	16		
General Safety	03		
Greasing	15		
Greasing Wheel Bearings	19		
		H	
How the Machine Works	09		
Hydraulic Propeller Agitator	21		
Hydraulic Safety	05		
Hydraulic System	11		
		I	
Introduction	01		
Installation of the H5000/H6000 Pump	12		
Installation of Safety Decal	06		
		M	
Maintenance	18		
Maintenance Safety	04		
Manure Storage Facility Safety	06		
Mechanical Specifications	22		
		O	
Operation	09		
Operation of H5000/H6000 Pump	13		
Operating Safety	04		
Operator Orientation	01		
Options	21		
		P	
Placing in Storage	14		
Pre-Operation Checklist	10		
Principals of Operation	09		
PTO Driveline Servicing	16		
PTO Driveline Shear Pin	18		
PTO Safety Shield Maintenance	18		
		R	
Removing from Storage	14		
Removing Liquid Manure Pump	14		
		S	
Safety	03		
Safety Alert Symbol	02		
Safety Decal	06		
Safety Decal Locations	08		
Service	15		
Service and Maintenance	15		
Service Record	17		
Service Intervals	16		
Sign-Off Form	07		
Specifications	22		
Storage	14		
Storage Safety	06		
		T	
Tire Options	22		
Tire Safety	06		
To the New Operator or Owner	09		
Towing	10		
Tractor Horsepower Requirements	11		
Trailer Model Pump	12		
Transport Safety	05		
Trouble Shooting	20		
Two Point Hitch Model Pump	12		
Two Point Hitch Model Photo	21		
		V	
Vertical Deflector	21		
		W	
Wheel Bolt Torque	22		

10 PARTS BOOK

The Parts Book with a list of all the parts on your pump is enclosed with this manual at the time you purchase the pump new.

Contact your local dealer or the factory if you need a copy of the parts book or you need a new copy of this operator's manual

At the time of printing there is no charge for these books to an owner of Husky Liquid Manure Equipment.

HUSKY FARM EQUIPMENT LIMITED

R.R. # 2 ALMA, ONTARIO N0B 1A0

Phone(519) 846-5329 Fax (519) 846-9378

ISSUE DATE: APRIL, 1995

PRINTED IN CANADA

PART NUMBER: 242-00-00-300