

Date Purchased \_\_\_\_\_ Machine Serial No. \_\_\_\_\_

Size of Pipe Cart \_\_\_\_\_ Options \_\_\_\_\_

The key number system in this parts book is arranged as follows:

- ◎ -- Key numbers with two circles denotes main assemblies.
- -- Key numbers with one circle are individual parts.

Please order parts by part number.



### **Pump Mount Pipe Cart**

**258-00-00-000 8"**  
**257-00-00-000 10"**

#### OPERATING INSTRUCTIONS:

1. Make sure clamps are securely fastened before operating to ensure hose won't blow off during filling
2. Always check tire pressure and wheel bolt torque before towing.
3. When towing lower Pipe all the way down for clearance from overhead power wires
4. Wash Pipe Cart off after each use. This will extend the life of the Pipe.
5. Depending on the amount of Highway travel the wheel bearings shall be greased annually
6. Make sure all manure is drained from pipe prior to freezing conditions

# 8" PUMP MOUNT DISCHARGE PIPE

8" PUMP MOUNT PIPE CART KIT  
258-00-00-000

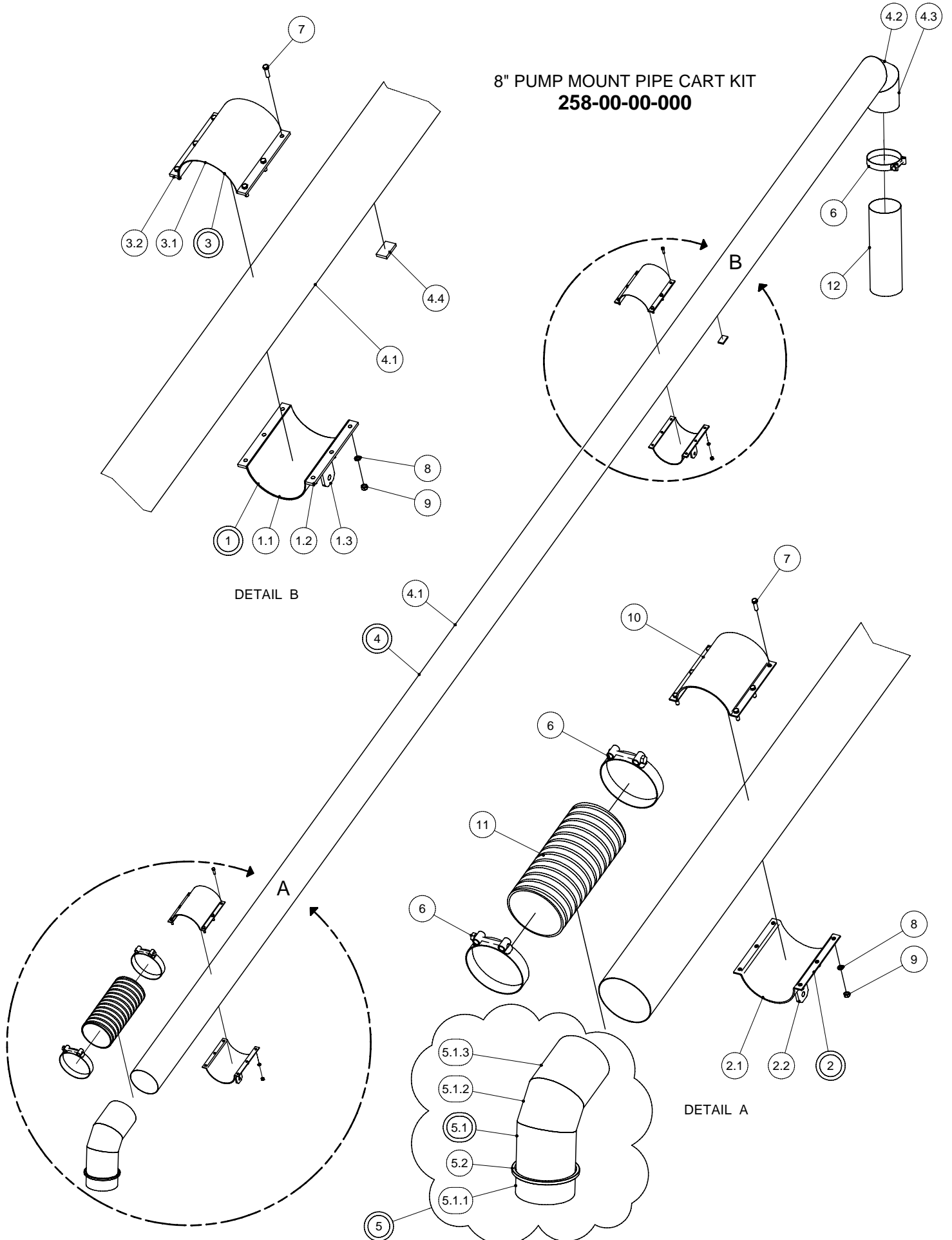

## 8" PUMP MOUNT DISCHARGE PIPE

PARTS LIST			
ITEM	PART NUMBER	DESCRIPTION	QTY
1	248-04-00-000	UPPER PIPE SLIDING CLAMP ASSY	1
1.1	248-04-01-018	UPPER CLAMP TUBE	1
1.2	248-04-01-019	UPPER CLAMP BOLT PLATE	2
1.3	248-03-00-017	UPPER CLAMP PIVOT BRKT	2
2	258-01-00-000	LOWER PIPE CLAMP ASSY	1
2.1	242-00-00-221	CONE CLAMP ON BRKT	1
2.2	248-03-00-017	UPPER CLAMP PIVOT BRKT	2
3	248-04-01-000	UPPER PIPE SLIDING CLAMP ASSY	1
3.1	248-04-01-018	UPPER CLAMP TUBE	1
3.2	248-04-01-019	UPPER CLAMP BOLT PLATE	2
4	258-02-00-000	8" DISCHARGE PIPE ASSY	1
4.1	258-02-00-001	8" ALUMINUM DISCHARGE TUBE	1
4.2	258-02-00-002	DISCHARGE PIPE ELBOW PC	1
4.3	258-02-00-003	DISCHARGE PIPE END PC	1
4.4	248-05-00-038	STOP LUG	1
5	244-08-00-000	PUMP ELBOW w/ RING ASSY	1
5.1	242-28-00-000	PUMP ELBOW ASSY	1
5.1.1	242-28-00-138	PUMP ELBOW BASE SECTION	1
5.1.2	242-28-00-139	PUMP ELBOW MIDDLE SECTION	1
5.1.3	242-28-00-140	PUMP ELBOW UPPER SECTION	1
5.2	244-08-00-307	CLAMP RING	1
6	R02484	8" SUCTION HOSE CLAMP	3
7	R07629	7/16 x 1 1/2 UNC HEX BOLT	12
8	R07804	7/16" LOCK WASHER	12
9	R07784	7/16-14 UNC HEX NUT	12
10	242-00-00-221	CONE CLAMP ON BRKT	1
11	242-00-00-141	FLEXIBLE HOSE SECTION	1
12	248-00-00-069	8" DISCHARGE PIPE FLEX HOSE	1



# 10" PUMP MOUNT DISCHARGE PIPE

PARTS LIST			
ITEM	PART NUMBER	DESCRIPTION	QTY
1	257-02-00-000	LOWER CLAMP ASSY	1
1.1	248-08-01-000	LOWER OUTER CLAMP ASSY	1
1.1.1	248-08-01-025	10" LOWER CLAMP PC	1
1.1.2	248-04-01-019	UPPER CLAMP BOLT PLATE	2
1.2	248-03-00-017	UPPER CLAMP PIVOT BRKT	2
2	248-09-00-000	UPPER INNER CLAMP ASSY	1
2.1	248-09-01-000	UPPER OUTER CLAMP ASSY	1
2.1.1	248-09-01-026	UPPER CLAMP HALF TUBE - 10"	1
2.1.2	248-04-01-019	UPPER CLAMP BOLT PLATE	2
2.2	248-03-00-017	UPPER CLAMP PIVOT BRKT	2
3	257-03-00-000	DISCHARGE PIPE ASSY-10"	1
3.1	257-03-00-010	DISCHARGE TUBE	1
3.2	257-03-00-011	DISCHARGE PIPE ELBOW PC	1
3.3	257-03-00-012	DISCHARGE PIPE END PC	1
3.4	248-05-00-038	STOP LUG	1
4	R02492	10" SUPER CLAMP	3
5	248-08-01-000	LOWER OUTER CLAMP ASSY	1
5.1	248-08-01-025	10" LOWER CLAMP PC	1
5.2	248-04-01-019	UPPER CLAMP BOLT PLATE	2
6	248-09-01-000	UPPER OUTER CLAMP ASSY	1
6.1	248-09-01-026	UPPER CLAMP HALF TUBE - 10"	1
6.2	248-04-01-019	UPPER CLAMP BOLT PLATE	2
7	286-27-00-000	10" TO 8" ALUMINUM PUMP ELBOW ASSY	1
7.2	248-28-00-075	REDUCER TUBE	1
7.3	R02536	8" MALE ALUM. BANDLOCK RING	1
7.4	248-28-00-076	ALUMINUM REDUCER RING	1
7.5	286-27-00-091	ALUMINUM PIPE ELBOW BASE PC	1
7.6	248-24-00-073	ALUMINUM ELBOW END PC-10"	1
7.7	248-24-00-072	ALUMINUM ELBOW MIDD PC-10"	1
8	286-10-02-000	10" ALUMINUM PUMP ELBOW ASSY (OPTIONAL)	1
9	286-10-00-047	10" FLEX HOSE	1
10	248-00-00-070	10" FLEX HOSE FOR TOP OF PIPE CART	1
11	R07629	7/16 x 1 1/2 UNC HEX BOLT	6
12	R07804	7/16" LOCK WASHER	12
13	R07784	7/16-14 UNC HEX NUT	12
14	R07630	7/16 x 2 UNC HEX BOLT	6



# PUMP MOUNT CART FRAME

PARTS LIST			
ITEM	PART NUMBER	DESCRIPTION	QTY
1	257-01-00-000	FRAME ASSY	1
1.1	257-01-01-000	AXLE ASSY	1
1.1.1	250-64-27-000	SPINDLE ASSY	2
1.1.1.1	R20141	SPINDLE	1
1.1.1.2	250-64-27-149	PLUG WASHER	2
1.1.2	257-01-01-013	AXLE TUBE	1
1.2	257-01-00-001	OUTER FRAME ARM	2
1.3	248-01-02-009	AXLE MOUNT TUBE	2
1.4	257-01-00-002	INNER FRAME ARM	2
1.5	257-01-00-003	INNER FRAME PIVOT BRKT	2
1.6	257-01-00-004	GUSSET PLATE	2
1.7	248-01-02-012	CABLE BRKT	1
1.8	248-01-01-006	OUTER TONGUE TUBE	1
1.9	257-01-00-006	ADJUSTMENT TUBE	1
1.10	257-01-00-007	SHORT CROSS TUBE	1
1.11	248-01-01-037	WINCH BRKT	1
1.12	248-01-00-014	STOP TUBE	2
1.13	257-01-00-015	LONG CROSS TUBE	1
2	250-60-30-000	H-411 HUB COMPLETE	2
3	250-65-00-000	TIRE & WHEEL ASSY - 5.9 x 15	2
4	248-02-00-000	TONGUE ASSY	1
4.1	248-02-00-015	TONGUE TUBE	1
4.2	248-02-00-016	TONGUE PLATE	2
5	206-03-00-000	TONGE PIN ASSY	2
5.1	206-03-00-019	TONGE PIN	1
5.2	250-00-00-354	1/4 X 1 1/2" RING	1
6	257-00-00-009	VERTICAL SUPPORT TUBE	1
7	R10350	1 TON WORM GEAR WINCH	1
8	R07652	5/8 x 5 UNC HEX BOLT	2
9	R07948	5/32 HAIR PIN	2
10	R08077	3/16" CABLE CLAMP	2
11	257-00-00-014	3/16" LIFT CABLE	1
12	R07619	3/8 x 1 UNC HEX BOLT	3
13	R07823	3/8" FLAT WASHER	3
14	R07794	3/8-16 UNC FLANGE NUT	3
15	R09071	SERIAL NUMBER PLATE	1
16	R08152	6 x 1/4 PAN HD SOCKET SCREW	2
17	R08207	5/32 x 1 1/2 S.S. COTTER PIN	2
18	R20142	SLOTTED HEX NUT	2
19	R07887	5/8-11 UNC 2-WAY LOCK NUT	2
20	257-00-00-018	CLAMP SPACER TUBE	2

## TIRE, WHEEL AND HUB

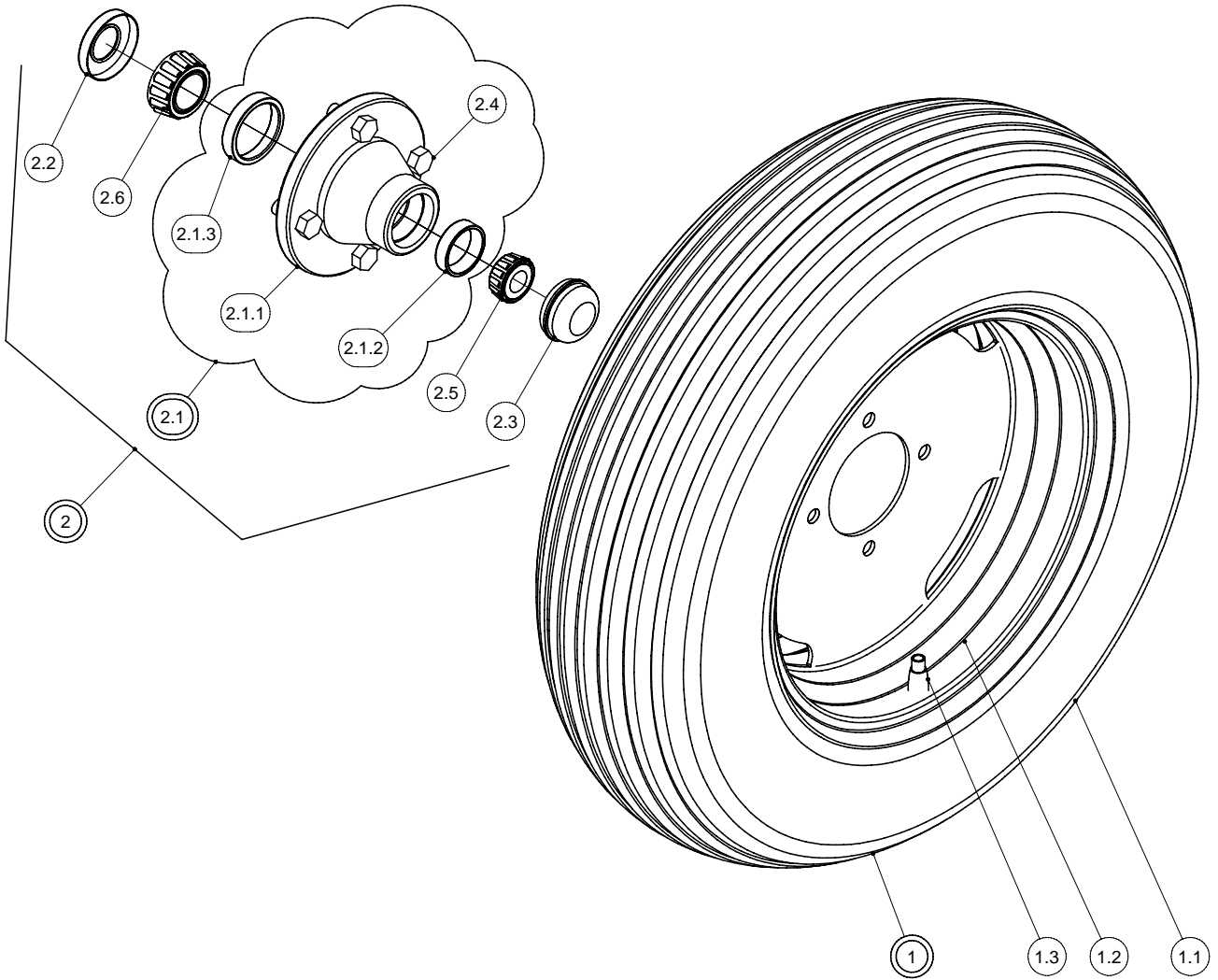

PARTS LIST			
ITEM	PART NUMBER	DESCRIPTION	QTY
1	250-65-00-000	TIRE & WHEEL ASSY - 5.9 x 15	1
1.1	R20016	5.9 x 15 RIB IMPLEMENT TIRE	1
1.2	R20057	4.5 x 15 WHEEL - 4 BOLT	1
1.3	R20020	VALVE STEM	1
2	250-60-30-000	H-411 HUB COMPLETE	1
2.1	R20139	H-411 HUBS w/ CUPS	1
2.1.1	R20160	H411 4 - BOLT HUB	1
2.1.2	R20130	LM11910 O.CUP	1
2.1.3	R20129	LM67010 I.CUP	1
2.2	R20144	OIL SEAL	1
2.3	R20143	DUST CAP	1
2.4	R20145	WB55 1/2 x 1 WHEEL BOLT	4
2.5	R20158	LM67048 OUTER CONE	1
2.6	R20159	LM29748 INNER CONE	1