

Date Purchased _____ Machine Serial No. _____

Size of Pipe Cart _____ Options _____

The key number system in this parts book is arranged as follows:

- ◎ -- Key numbers with two circles denotes main assemblies.
- -- Key numbers with one circle are individual parts.

Please order parts by part number.



Heavy Duty Pipe Cart

247-00-00-000 8"

245-00-00-000 10"

OPERATING INSTRUCTIONS:

1. Make sure clamps are securely fastened before operating to ensure hose won't blow off during filling
2. Always check tire pressure and wheel bolt torque before towing.
3. When towing lower Pipe all the way down for clearance from overhead power wires
4. Wash Pipe Cart off after each use. This will extend the life of the Pipe.
5. Depending on the amount of Highway travel the wheel bearings shall be greased annually
6. Make sure all manure is drained from pipe prior to freezing conditions

8" HD DISCHARGE PIPE

8" HD DISCHARGE PIPE CART KIT 247-00-00-000

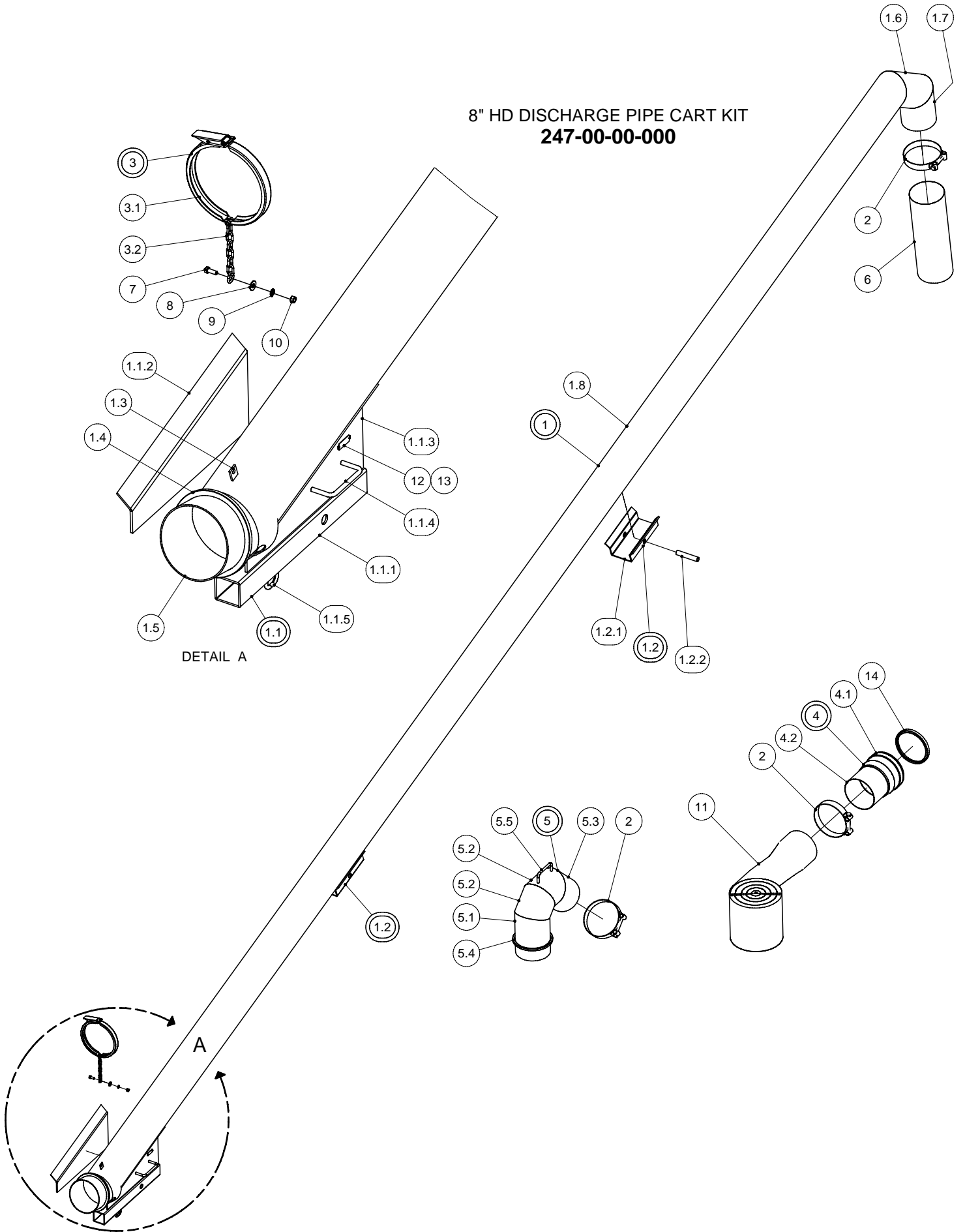

8" HD DISCHARGE PIPE

PARTS LIST			
ITEM	PART NUMBER	DESCRIPTION	QTY
1	247-02-00-000	8" DISCHARGE PIPE ASSY COMPLETE	1
1.1	247-02-01-000	TONGUE BRKT ASSY	1
1.1.1	247-02-01-012	TONGUE BRKT TUBE	1
1.1.2	247-02-01-013	RH TONGUE BRKT	1
1.1.3	247-02-01-014	LH TONGUE BRKT	1
1.1.4	244-12-03-341	CONE HANDLE	2
1.1.5	247-02-01-015	3/8" COIL CHAIN LINK	1
1.2	247-02-02-000	PIVOT BRKT ASSY-8" PIPE	2
1.2.1	247-02-02-016	PIVOT BRKT-8" PIPE	1
1.2.2	247-02-02-017	PIVOT BRKT SLEEVE	1
1.3	250-96-00-298	CHAIN LUG	1
1.4	244-08-00-307	CLAMP RING	1
1.5	247-02-03-021	PIPE BASE PC	1
1.6	247-02-03-019	TOP ELBOW MID PC	1
1.7	247-02-03-020	TOP ELBOW END PC	1
1.8	247-02-03-018	LONG DISCHARGE PIPE	1
2	R02484	8" SUCTION HOSE CLAMP	3
3	244-09-00-000	8" CLAMP & CHAIN ASSY	1
3.1	R02488	8" RINGLOCK CLAMP	1
3.2	250-97-00-297	CLAMP CHAIN	1
4	248-14-00-000	BELL AND DISCHARGE PIPE ASSY	1
4.1	R02982	8" RW COUPLER-NARROW	1
4.2	248-14-00-034	8" EXTENSION PIPE	1
5	248-06-00-000	8" - 45° ALUMINUM PUMP ELBOW W/RING ASSY	1
5.1	248-06-00-024 A	ELBOW PC - A	1
5.2	248-06-00-024 B	ELBOW PC - B	2
5.3	248-06-00-024 C	ELBOW PC - C	1
5.4	R02536	8" MALE ALUM. BANDLOCK RING	1
5.5	248-24-00-074	ALUMINUM HANDLE	1
6	248-00-00-069	8" DISCHARGE PIPE FLEX HOSE	1
7	R07619	3/8 x 1 UNC HEX BOLT	1
8	R07823	3/8" FLAT WASHER	1
9	R07803	3/8" LOCK WASHER	1
10	R07783	3/8-16 UNC HEX NUT	1
11	247-00-00-038	20 FT OF 8" BLK CONTRACTOR HOSE	1
12	R09071	SERIAL NUMBER PLATE	1
13	R08152	6 x 1/4 PAN HD SOCKET SCREW	2
14	R02360	8" SQ RAINWAY/HUSKY GASKET	1

10" HD DISCHARGE PIPE

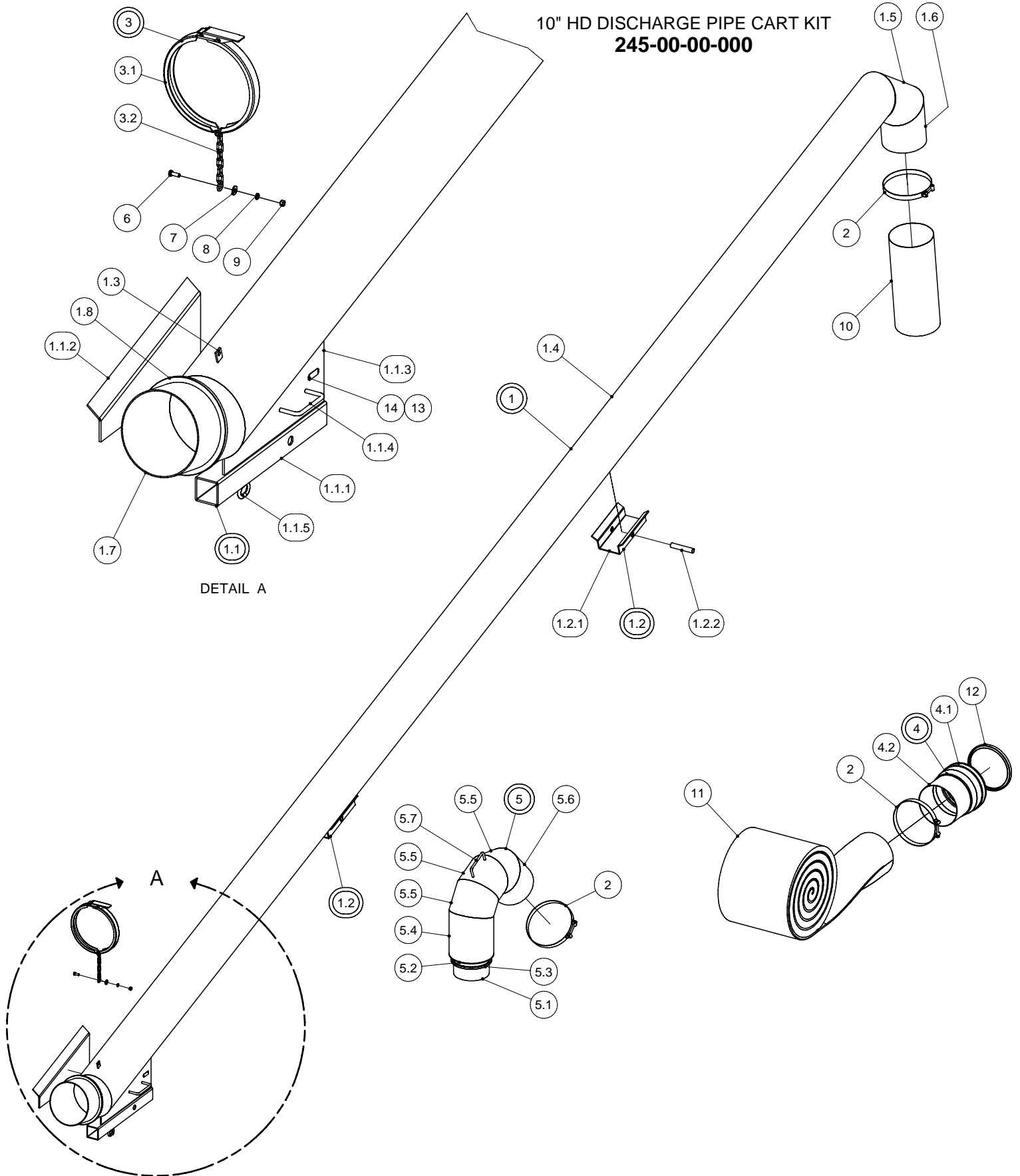

10" HD DISCHARGE PIPE

PARTS LIST			
ITEM	PART NUMBER	DESCRIPTION	QTY
1	245-01-00-000	10" DISCHARGE PIPE ASSY COMPLETE	1
1.1	247-02-01-000	TONGUE BRKT ASSY	1
1.1.1	247-02-01-012	TONGUE BRKT TUBE	1
1.1.2	247-02-01-013	RH TONGUE BRKT	1
1.1.3	247-02-01-014	LH TONGUE BRKT	1
1.1.4	244-12-03-341	CONE HANDLE	2
1.1.5	247-02-01-015	3/8" COIL CHAIN LINK	1
1.2	245-01-02-000	10" PIVOT BRKT ASSY	2
1.2.1	245-01-02-005	PIVOT BRKT-10" PIPE	1
1.2.2	247-02-02-017	PIVOT BRKT SLEEVE	1
1.3	250-96-00-298	CHAIN LUG	1
1.4	245-01-01-001	10" LONG DISCHARGE PIPE	1
1.5	245-01-01-002	TOP ELBOW MID PC	1
1.6	245-01-01-003	TOP ELBOW END PC	1
1.7	245-01-01-004	PIPE BASE PC	1
1.8	286-00-00-059	RING FOR STEEL ELBOW	1
2	R02492	10" SUPER CLAMP	3
3	286-13-00-000	10" CLAMP AND CHAIN ASSY	1
3.1	R02500	10" BANDLOC CLAMP	1
3.2	250-97-00-297	CLAMP CHAIN	1
4	248-15-00-000	10" BELL AND EXTENSION PIPE ASSY	1
4.1	R02983	10" RW COUPLER-NARROW	1
4.2	248-15-00-035	10" EXTENSION PIPE	1
5	248-10-00-000	10" ELBOW ASSY	1
5.1	248-10-00-029	REDUCING TUBE	1
5.2	248-10-00-028	REDUCER RING	1
5.3	244-08-00-307	CLAMP RING	1
5.4	248-10-00-027 A	ELBOW PC A	1
5.5	248-10-00-027 B	ELBOW PC B	3
5.6	248-10-00-027 C	ELBOW PC C	1
5.7	244-12-03-341	CONE HANDLE	1
6	R07619	3/8 x 1 UNC HEX BOLT	1
7	R07823	3/8" FLAT WASHER	1
8	R07803	3/8" LOCK WASHER	1
9	R07783	3/8-16 UNC HEX NUT	1
10	248-00-00-070	10" FLEX HOSE FOR TOP OF PIPE CART	1
11	245-00-00-006	20 FT OF 10" BLK CONTRACTOR HOSE	1
12	R02849	10" RW GASKET	1
13	R09071	SERIAL NUMBER PLATE	1
14	R08152	6 x 1/4 PAN HD SOCKET SCREW	2

HD PIPE CART FRAME

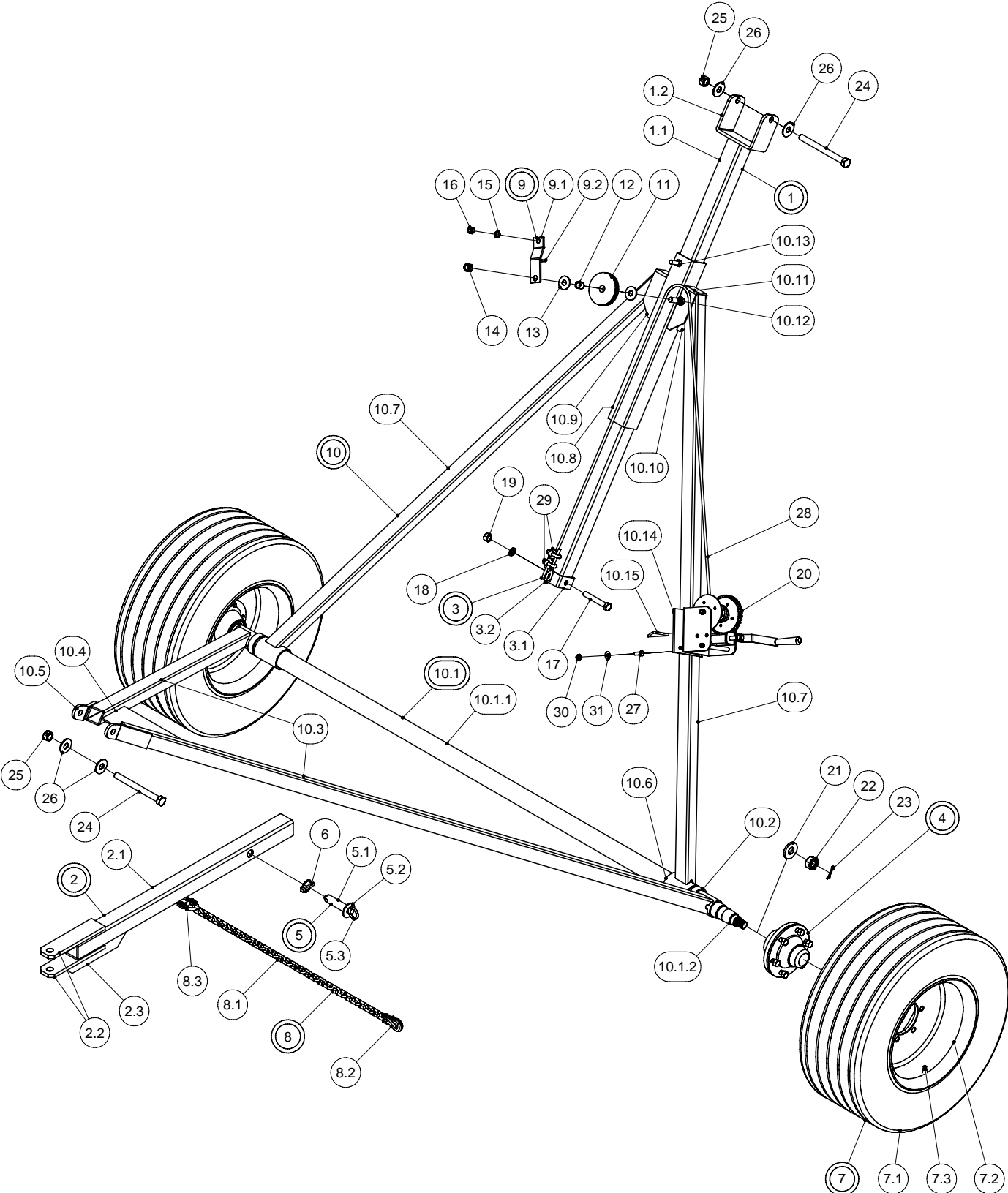

HD PIPE CART FRAME

PARTS LIST				PARTS LIST			
ITEM	PART NUMBE	DESCRIPTION	QTY	ITEM	PART NUMBE	DESCRIPTION	QTY
1	247-03-00-000	EXTENSION TUBE ASSY	1	10.4	247-01-00-004	GUSSET	1
1.1	247-03-00-022	EXTENSION TUBE	1	10.5	247-01-00-005	TUBE BRKT	2
1.2	247-03-00-023	EXT TUBE "U" BRKT	1	10.6	247-01-00-006	SLEEVE	2
2	247-04-00-000	TONGUE ASSY	1	10.7	247-01-00-007	INNER ARM	2
2.1	247-04-00-024	TONGUE TUBE	1	10.8	247-01-00-008	STUB TUBE	1
2.2	247-04-00-025	HITCH PLATE	2	10.9	247-01-00-009	INNER ARM L.H. CAP	1
2.3	247-04-00-026	REINFORCING PLATE	1	10.10	247-01-00-011	LOWER INNER ARM CAP	2
3	247-05-00-000	CABLE BRKT ASSY	1	10.11	247-01-00-010	INNER ARM R.H. CAP	1
3.1	247-05-00-029	CABLE BRKT TUBE	1	10.12	R07647	5/8 x 2" HEX BOLT	1
3.2	247-05-00-032	CABLE ATTACHMENT LINK	1	10.13	R07638	1/2 x 1 1/2 HEX BOLT	1
4	290-59-00-000	5000LB - 6 BOLT HUB ASSY	2	10.14	247-01-00-031	WINCH BRKT	1
5	247-06-00-000	TONGUE PIN ASSY	1	10.15	247-01-00-030	WINCH BRKT GUSSET	1
5.1	247-06-00-034	TONGUE PIN	1	11	247-00-00-027	PULLEY	1
5.2	R07827	3/4" FLAT WASHER	1	12	R21167	7/8 OD x 5/8 ID x 3/4 LONG BUSHING	1
5.3	R07925	1/4 x 1 1/2 PLATED RING	1	13	R07826	5/8" FLAT WASHER	2
6	R08040	2 - 18 LYNCH PIN	1	14	R07887	5/8-11 UNC 2-WAY LOCK NUT	1
7	247-07-00-000	TIRE & WHEEL ASSY P275/60R15	2	15	R07805	1/2" LOCK WASHER	1
7.1	R22560	P275 60R15 PASSENGER TIRE	1	16	R07785	1/2-13 UNC HEX NUT	1
7.2	R20045	15 x 8 x 6 BOLT WHEEL	1	17	R07651	5/8 x 4 UNC HEX BOLT	1
7.3	R20020	VALVE STEM	1	18	R07806	5/8" LOCK WASHER	1
8	247-09-00-000	SAFETY CHAIN KIT	2	19	R07786	5/8-11 UNC HEX NUT	1
8.1	247-09-00-036	SAFETY CHAIN	1	20	R10350	1 TON WORM GEAR WINCH	1
8.2	R08092	5/16" HOOK	1	21	R20118	SPINDLE WASHER	2
8.3	R08215	1/4" CONNECTING LINK	1	22	R20117	SPINDLE NUT	2
9	247-10-00-000	PULLEY BRKT ASSY	1	23	R08013	3/16 x 2 COTTER PIN	2
9.1	247-10-00-028	PULLEY BRKT	1	24	R08336	3/4 x 8 UNC HEX BOLT	2
9.2	247-10-00-037	PULLEY BRKT "L" PLATE	1	25	R07881	3/4-10 UNC 2-WAY LOCK NUT	2
10	247-01-00-000	MAIN FRAME ASSY	1	26	R07827	3/4" FLAT WASHER	4
10.1	247-01-01-000	AXLE TUBE W/SPINDLES ASSY	1	27	R07619	3/8 x 1 UNC HEX BOLT	3
10.1.1	247-01-01-001	CROSS TUBE	1	28	247-00-00-035	5/16" WINCH CABLE	1
10.1.2	247-01-01-033	SPINDLE	2	29	R08072	5/16 CABLE CLAMP	2
10.2	247-01-00-002	STOP TUBE	2	30	R07794	3/8-16 UNC FLANGE NUT	3
10.3	247-01-00-003	OUTER ARM	2	31	R07823	3/8" FLAT WASHER	3

5000LB 6 BOLT HUB ASSY

290-59-00-000
5000LB - 6 BOLT HUB ASSY

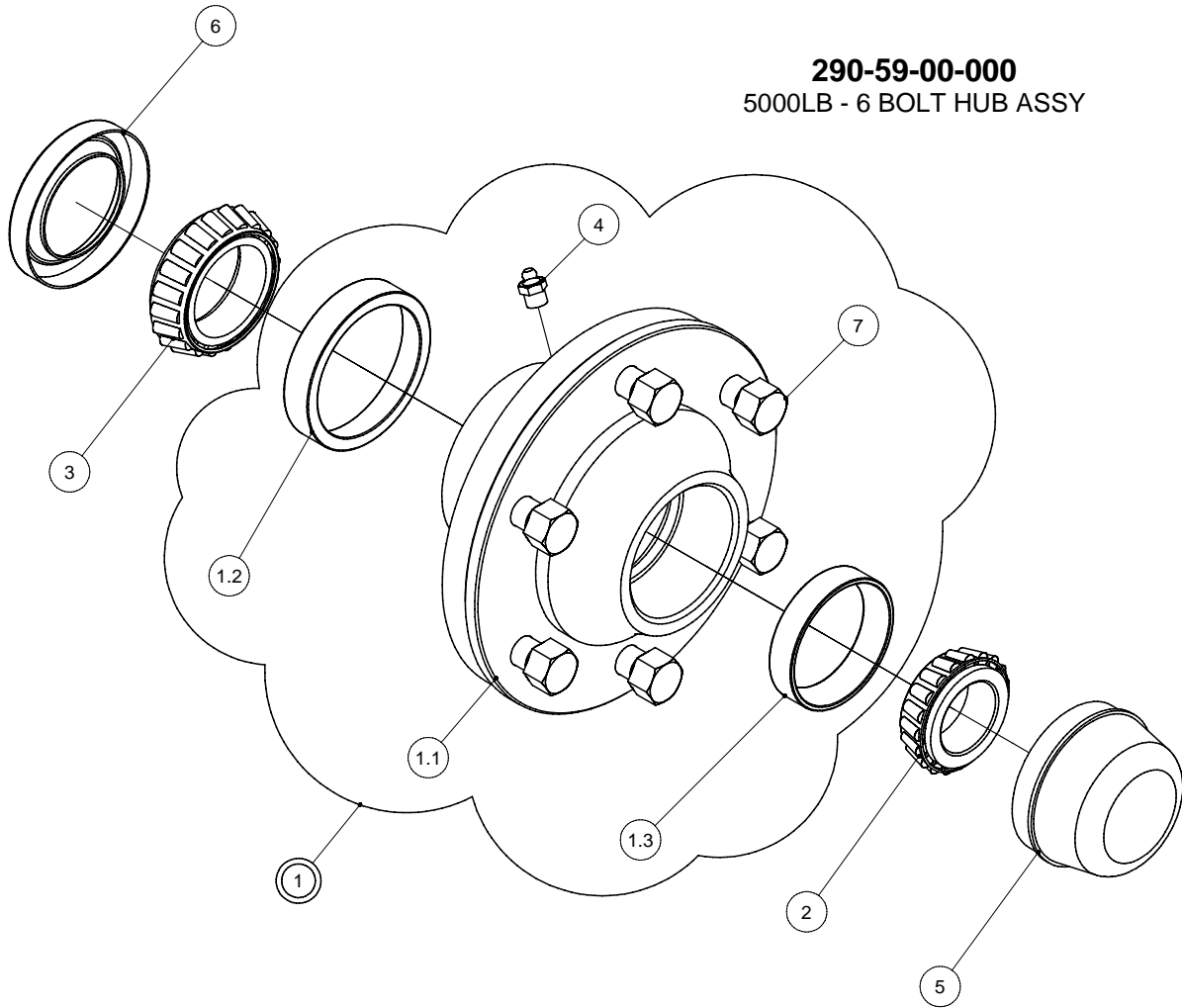

PARTS LIST			
ITEM	PART NUMBER	DESCRIPTION	QTY
1	R22055	5000LB HUB w/ CUPS	1
1.1	R22054	5000LB HUB - 6 BOLT	1
1.2	R22058	INNER CUP LM603049	1
1.3	R22060	OUTER CUP LM48510	1
2	R22061	OUTER CONE LM48548	1
3	R22059	INNER CONE LM603049	1
4	R08186	1/8" NPT GREASE FTG	1
5	R22062	DUST CAP	1
6	R22063	SEAL CR2004	1
7	R20110	9/16 UNF WHEEL BOLT	6