

Date Purchased \_\_\_\_\_ Machine Serial No. \_\_\_\_\_

Size of Pipe Cart \_\_\_\_\_ Options \_\_\_\_\_

The key number system in this parts book is arranged as follows:

- ◎ -- Key numbers with two circles denotes main assemblies.
- -- Key numbers with one circle are individual parts.

Please order parts by part number.



### Pipe Cart

**248-00-00-000 8"**  
**249-00-00-000 10"**

#### OPERATING INSTRUCTIONS:

1. Make sure clamps are securely fastened before operating to ensure hose won't blow off during filling
2. Always check tire pressure and wheel bolt torque before towing.
3. When towing lower Pipe all the way down for clearance from overhead power wires
4. Wash Pipe Cart off after each use. This will extend the life of the Pipe.
5. Depending on the amount of Highway travel the wheel bearings shall be greased annually
6. Make sure all manure is drained from pipe prior to freezing conditions

# 8" DISCHARGE PIPE

## 8" DISCHARGE PIPE CART KIT 248-00-00-000

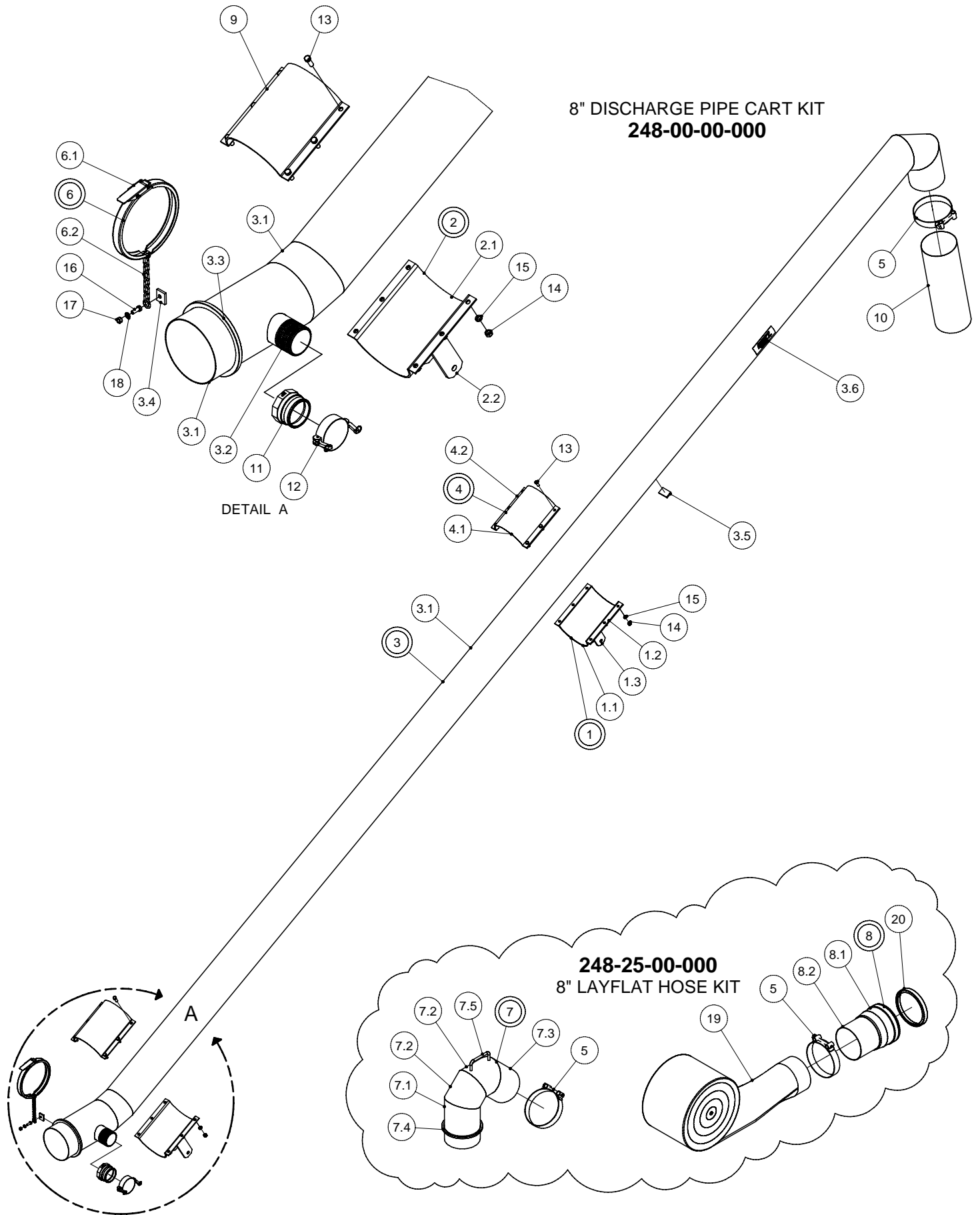

## 8" DISCHARGE PIPE

PARTS LIST			
ITEM	PART NUMBER	DESCRIPTION	QTY
1	248-04-00-000	UPPER PIPE SLIDING CLAMP ASSY	1
1.1	248-04-01-018	UPPER CLAMP TUBE	1
1.2	248-04-01-019	UPPER CLAMP BOLT PLATE	2
1.3	248-03-00-017	UPPER CLAMP PIVOT BRKT	2
2	248-03-00-000	LOWER PIPE CLAMP ASSY	1
2.1	242-00-00-221	CONE CLAMP ON BRKT	1
2.2	248-03-00-050	LOWER CLAMP PIVOT BRKT	2
3	248-05-00-000	8" DISCHARGE PIPE ASSY	1
3.1	248-05-00-020	8" DISCHARGE PIPE	1
3.2	R02097	3" x 4" LONG TOE ALUM. NIPPLE	1
3.3	R02536	8" MALE ALUM. BANDLOCK RING	1
3.4	248-05-00-036	CHAIN LUG	1
3.5	248-05-00-038	STOP LUG	1
3.6	R09502	"HUSKY" DECAL	1
4	248-04-01-000	UPPER PIPE SLIDING CLAMP ASSY	1
4.1	248-04-01-018	UPPER CLAMP TUBE	1
4.2	248-04-01-019	UPPER CLAMP BOLT PLATE	2
5	R02484	8" SUCTION HOSE CLAMP	3
6	244-09-00-000	8" CLAMP & CHAIN ASSY	1
6.1	R02488	8" RINGLOCK CLAMP	1
6.2	250-97-00-297	CLAMP CHAIN	1
7	248-06-00-000	8" - 45° ALUMINUM PUMP ELBOW W/RING ASSY	1
7.1	248-06-00-024 A	ELBOW PC - A	1
7.2	248-06-00-024 B	ELBOW PC - B	2
7.3	248-06-00-024 C	ELBOW PC - C	1
7.4	R02536	8" MALE ALUM. BANDLOCK RING	1
7.5	248-24-00-074	ALUMINUM HANDLE	1
8	248-14-00-000	BELL AND DISCHARGE PIPE ASSY	1
8.1	R02982	8" RW COUPLER-NARROW	1
8.2	248-14-00-034	8" EXTENSION PIPE	1
9	242-00-00-221	CONE CLAMP ON BRKT	1
10	248-00-00-069	8" DISCHARGE PIPE FLEX HOSE	1
11	R02778	3" CAMLOCK M->F NPT	1
12	R02784	3" F CAMLOCK CAP	1
13	R07671	7/16 x 1 1/4 UNC HEX BOLT	12
14	R07784	7/16-14 UNC HEX NUT	12
15	R07804	7/16" LOCK WASHER	12
16	R07619	3/8 x 1 UNC HEX BOLT	1
17	R07783	3/8-16 UNC HEX NUT	1
18	R07803	3/8" LOCK WASHER	1
19	248-00-00-021	8" PVC LAYFLAT HOSE	1
20	R02497	8" RAINWAY GASKET	1

# 10" DISCHARGE PIPE

10" DISCHARGE PIPE CART KIT  
**249-00-00-000**

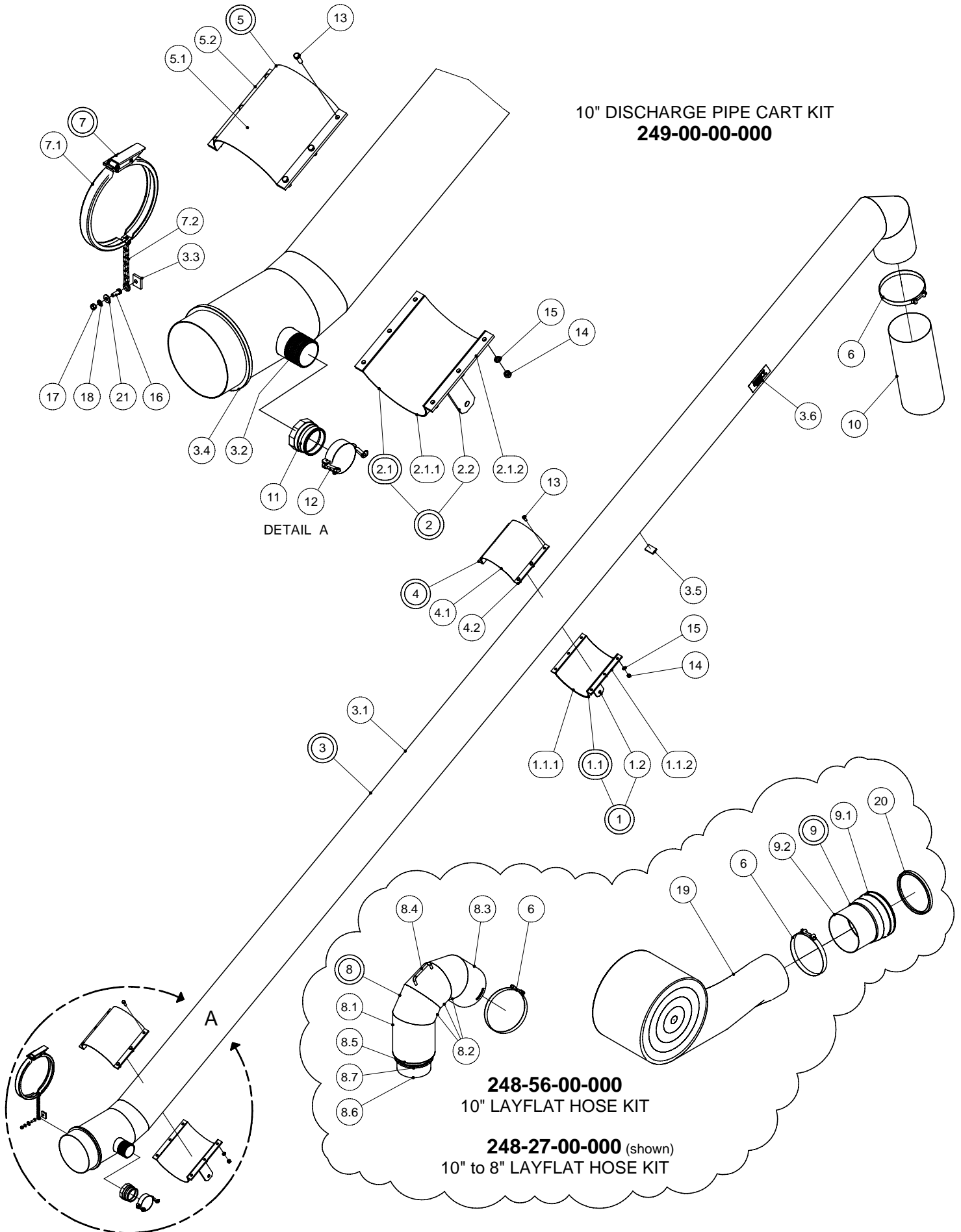

DETAIL A

**248-56-00-000**  
 10" LAYFLAT HOSE KIT

**248-27-00-000** (shown)  
 10" to 8" LAYFLAT HOSE KIT

# 10" DISCHARGE PIPE

PARTS LIST			
ITEM	PART NUMBER	DESCRIPTION	QTY
1	248-09-00-000	UPPER INNER CLAMP ASSY	1
1.1	248-09-01-000	UPPER OUTER CLAMP ASSY	1
1.1.1	248-09-01-026	UPPER CLAMP HALF TUBE - 10"	1
1.1.2	248-04-01-019	UPPER CLAMP BOLT PLATE	2
1.2	248-03-00-017	UPPER CLAMP PIVOT BRKT	2
2	248-08-00-000	LOWER INNER CLAMP ASSY	1
2.1	248-08-01-000	LOWER OUTER CLAMP ASSY	1
2.1.1	248-08-01-025	10" LOWER CLAMP PC	1
2.1.2	248-04-01-019	UPPER CLAMP BOLT PLATE	2
2.2	248-03-00-050	LOWER CLAMP PIVOT BRKT	2
3	248-11-00-000	10" DISCHARGE PIPE ASSY	1
3.1	248-11-00-030	DISCHARGE PIPE	1
3.2	R02097	3" x 4" LONG TOE ALUM. NIPPLE	1
3.3	248-05-00-036	CHAIN LUG	1
3.4	R02504	10 ALUM. BANDLOCK RING	1
3.5	248-05-00-038	STOP LUG	1
3.6	R09502	"HUSKY" DECAL	1
4	248-09-01-000	UPPER OUTER CLAMP ASSY	1
4.1	248-09-01-026	UPPER CLAMP HALF TUBE - 10"	1
4.2	248-04-01-019	UPPER CLAMP BOLT PLATE	2
5	248-08-01-000	LOWER OUTER CLAMP ASSY	1
5.1	248-08-01-025	10" LOWER CLAMP PC	1
5.2	248-04-01-019	UPPER CLAMP BOLT PLATE	2
6	R02492	10" SUPER CLAMP	3
7	286-13-00-000	10" CLAMP AND CHAIN ASSY	1
7.1	R02500	10" BANDLOC CLAMP	1
7.2	250-97-00-297	CLAMP CHAIN	1
8	248-28-00-000	10"TO 8" ALUMINUM ELBOW ASSY	1
8.1	248-24-00-071	ALUMINUM ELBOW BASE PC-10"	1
8.2	248-24-00-072	ALUMINUM ELBOW MIDD PC-10"	3
8.3	248-24-00-073	ALUMINUM ELBOW END PC-10"	1
8.4	248-24-00-074	ALUMINUM HANDLE	1
8.5	248-28-00-076	ALUMINUM REDUCER RING	1
8.6	248-28-00-075	REDUCER TUBE	1
8.7	R02536	8" MALE ALUM. BANDLOCK RING	1
9	248-15-00-000	10" BELL AND EXTENSION PIPE ASSY	1
9.1	R02983	10" RW COUPLER-NARROW	1
9.2	248-15-00-035	10" EXTENSION PIPE	1
10	248-00-00-070	10"FLEX HOSE FOR TOP OF PIPE CART	1
11	R02778	3" CAMLOCK M->F NPT	1
12	R02784	3" F CAMLOCK CAP	1
13	R07671	7/16 x 1 1/4 UNC HEX BOLT	12
14	R07784	7/16-14 UNC HEX NUT	12
15	R07804	7/16" LOCK WASHER	12
16	R07619	3/8 x 1 UNC HEX BOLT	1
17	R07783	3/8-16 UNC HEX NUT	1
18	R07803	3/8" LOCK WASHER	1
19	248-00-00-031	10" PVC LAYFLAT HOSE	1
20	R02849	10" RW GASKET	1
21	R07823	3/8" FLAT WASHER	1

# PIPE CART FRAME

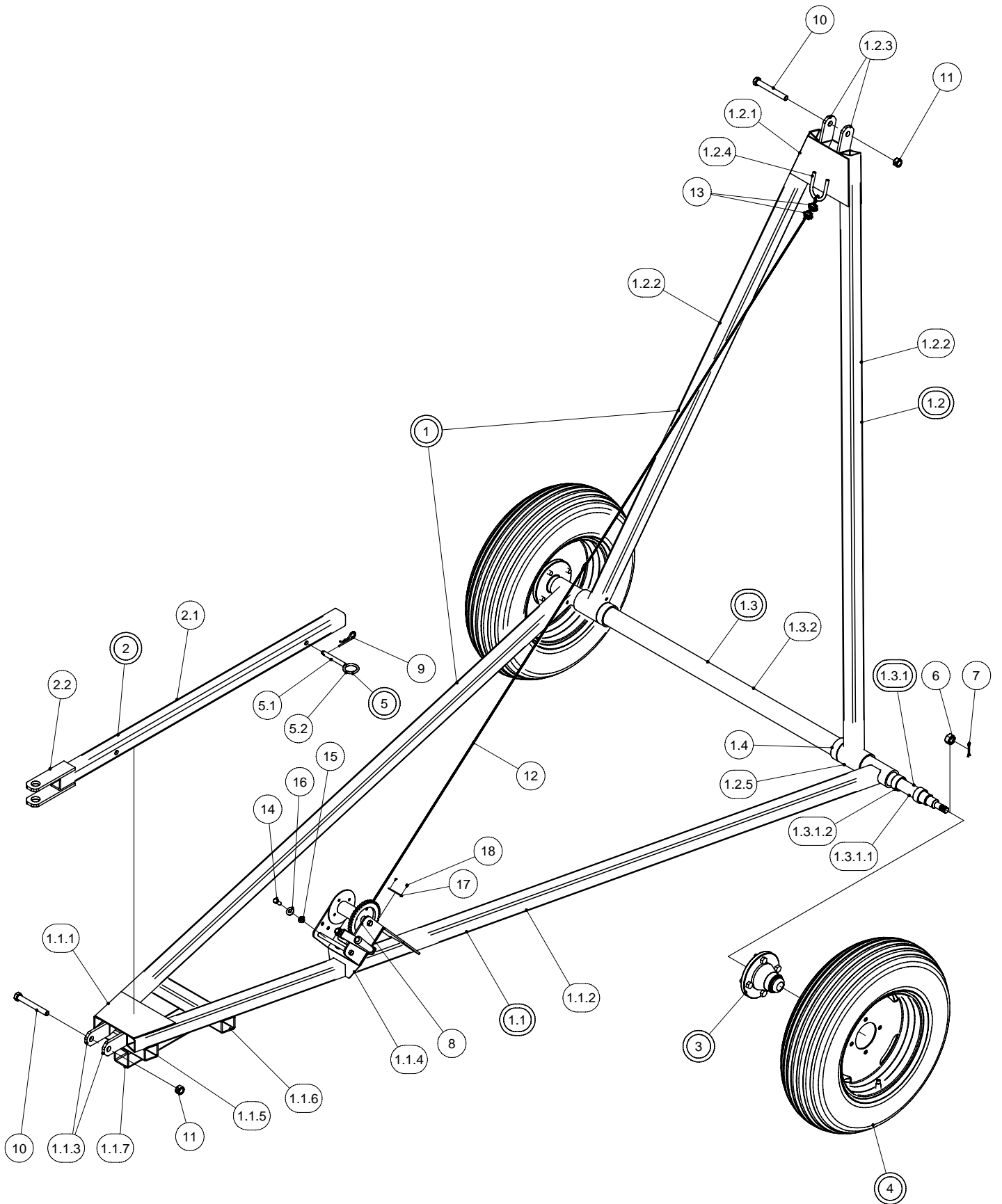

# PIPE CART FRAME

PARTS LIST			
ITEM	PART NUMBER	DESCRIPTION	QTY
1	248-01-00-000	TILT FRAME ASSY	1
1.1	248-01-01-000	OUTER FRAME ASSY	1
1.1.1	248-01-01-002	GUSSET	1
1.1.2	248-01-01-001	OUTER FRAME ARM	2
1.1.3	248-01-01-003	OUTER FRAME PIVOT BRKT	2
1.1.4	248-01-01-037	WINCH BRKT	1
1.1.5	248-01-01-004	SHORT CROSS TUBE	1
1.1.6	248-01-01-005	LONG CROSS TUBE	1
1.1.7	248-01-01-006	OUTER TONGUE TUBE	1
1.2	248-01-02-000	INNER FRAME ASSY	1
1.2.1	248-01-02-010	GUSSET	2
1.2.2	248-01-02-008	INNER FRAME LEG	2
1.2.3	248-01-02-011	INNER FRAME PIVOT BRKT	2
1.2.4	248-01-02-012	CABLE BRKT	1
1.2.5	248-01-02-009	AXLE MOUNT TUBE	2
1.3	248-01-03-000	AXLE ASSY	1
1.3.1	250-64-27-000	SPINDLE ASSY	2
1.3.1.1	R20141	SPINDLE	1
1.3.1.2	250-64-27-149	PLUG WASHER	2
1.3.2	248-01-03-023	AXLE TUBE	1
1.4	248-01-00-014	STOP TUBE	2
2	248-02-00-000	TONGUE ASSY	1
2.1	248-02-00-015	TONGUE TUBE	1
2.2	248-02-00-016	TONGUE PLATE	2
3	250-60-30-000	H-411 HUB COMPLETE	2
4	250-65-00-000	TIRE & WHEEL ASSY - 5.9 x 15	2
5	206-03-00-000	TONGE PIN ASSY	1
5.1	206-03-00-019	TONGE PIN	1
5.2	250-00-00-354	1/4 X 1 1/2" RING	1
6	R20142	SLOTTED HEX NUT	2
7	R08207	5/32 x 1 1/2 S.S. COTTER PIN	2
8	R10350	1 TON WORM GEAR WINCH	1
9	R07948	5/32 HAIR PIN	1
10	R07652	5/8 x 5 UNC HEX BOLT	2
11	R07887	5/8-11 UNC 2-WAY LOCK NUT	2
12	248-00-00-013	LIFT CABLE	1
13	R08077	3/16" CABLE CLAMP	2
14	R07619	3/8 x 1 UNC HEX BOLT	3
15	R07794	3/8-16 UNC FLANGE NUT	3
16	R07823	3/8" FLAT WASHER	3
17	R09071	SERIAL NUMBER PLATE	1
18	R08152	6 x 1/4 PAN HD SOCKET SCREW	2

## TIRE, WHEEL AND HUB

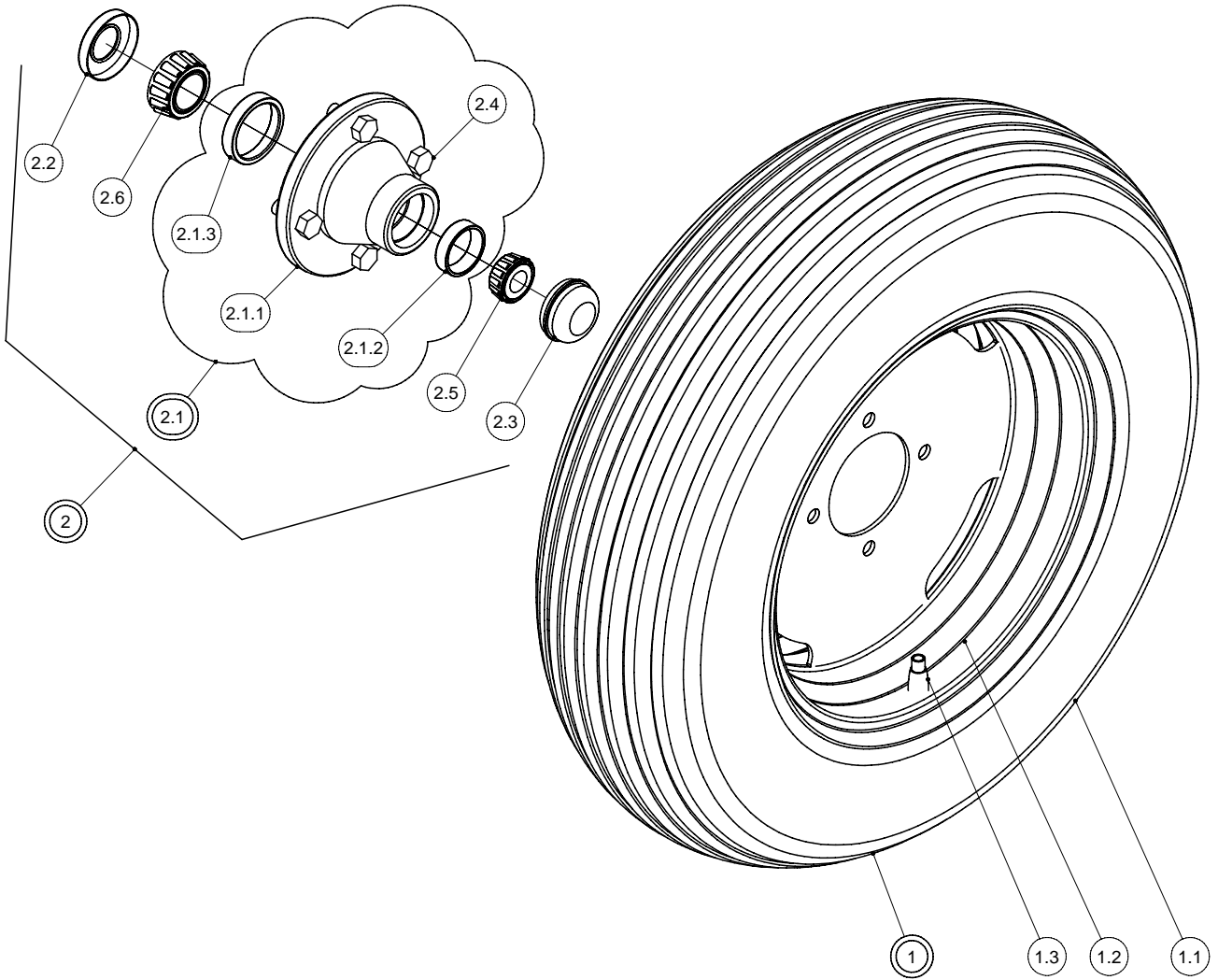

PARTS LIST			
ITEM	PART NUMBER	DESCRIPTION	QTY
1	250-65-00-000	TIRE & WHEEL ASSY - 5.9 x 15	1
1.1	R20016	5.9 x 15 RIB IMPLEMENT TIRE	1
1.2	R20057	4.5 x 15 WHEEL - 4 BOLT	1
1.3	R20020	VALVE STEM	1
2	250-60-30-000	H-411 HUB COMPLETE	1
2.1	R20139	H-411 HUBS w/ CUPS	1
2.1.1	R20160	H411 4 - BOLT HUB	1
2.1.2	R20130	LM11910 O.CUP	1
2.1.3	R20129	LM67010 I.CUP	1
2.2	R20144	OIL SEAL	1
2.3	R20143	DUST CAP	1
2.4	R20145	WB55 1/2 x 1 WHEEL BOLT	4
2.5	R20158	LM67048 OUTER CONE	1
2.6	R20159	LM29748 INNER CONE	1