

Date Purchased \_\_\_\_\_ Machine Serial No. \_\_\_\_\_

Size of Pipe Cart \_\_\_\_\_ Options \_\_\_\_\_

The key number system in this parts book is arranged as follows:

- ⊙ -- Key numbers with two circles denotes main assemblies.
- -- Key numbers with one circle are individual parts.

Please order parts by part number.



### Pipe Cart

**248-00-00-000 8"**

#### OPERATING INSTRUCTIONS:

1. Make sure clamps are securely fastened before operating to ensure hose won't blow off during filling
2. Always check tire pressure and wheel bolt torque before towing.
3. When towing lower Pipe all the way down for clearance from overhead power wires
4. Wash Pipe Cart off after each use. This will extend the life of the Pipe.
5. Depending on the amount of Highway travel the wheel bearings shall be greased annually
6. Make sure all manure is drained from pipe prior to freezing conditions

# 8" DISCHARGE PIPE

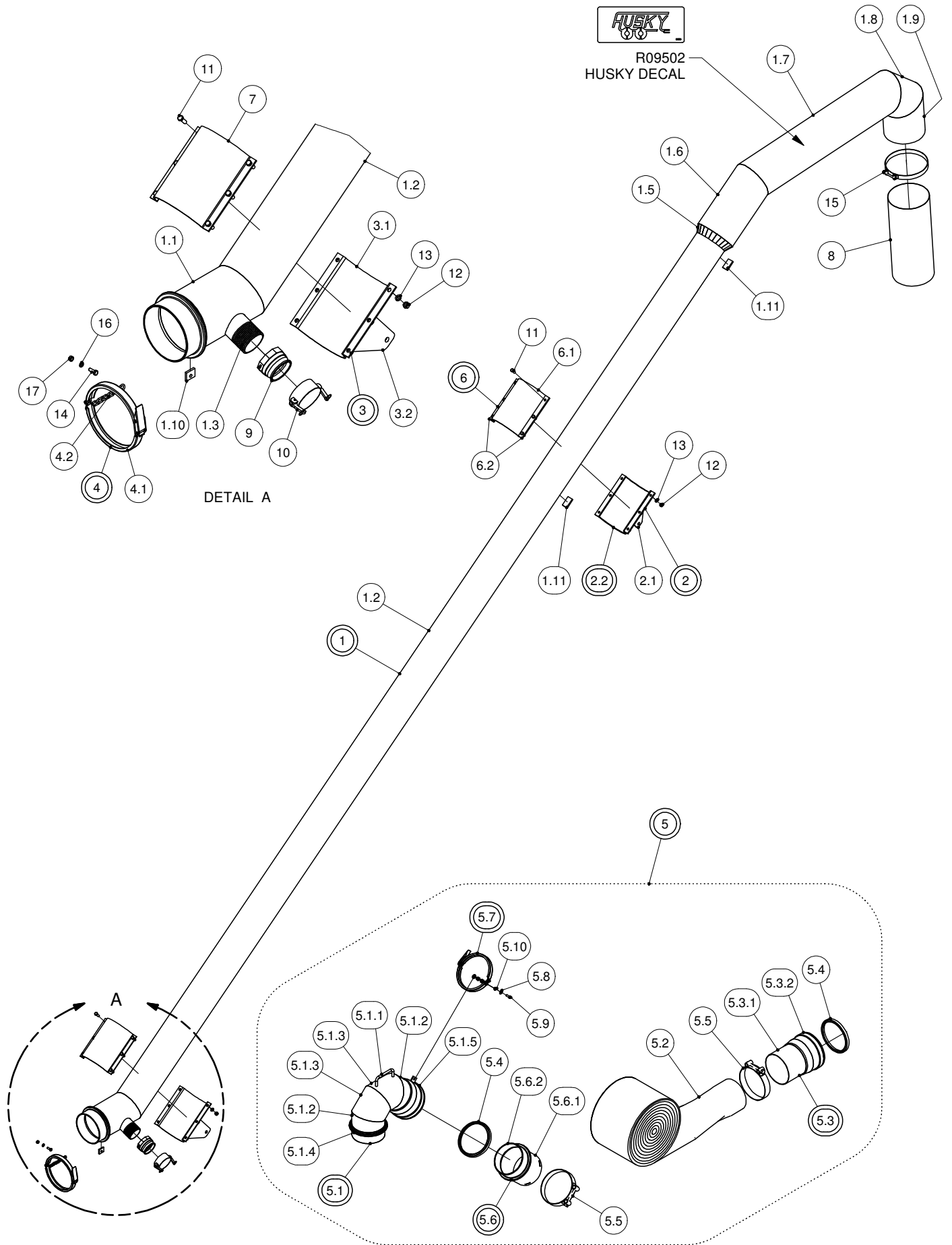

## 8" DISCHARGE PIPE

PARTS LIST				PARTS LIST			
ITEM	PART NUMBER	DESCRIPTION	QTY	ITEM	PART NUMBER	DESCRIPTION	QTY
1	248-34-00-000	8 TO 10" DISCH PIPE ASSY W/STR SECTION	1	5.1.4	R02989	8" CIRCLE LOCK, MALE ITHPM800	1
				5.1.5	R02982	8" RW COUPLER-NARROW	1
1.1	248-34-00-119	8" BOTTOM PIPE SECTION	1	5.1.6	248-05-00-036	CHAIN LUG	1
1.2	248-34-00-118	8" DISCHARGE PIPE	1	5.2	248-00-00-021	8" PVC LAYFLAT HOSE	1
1.3	R02097	3" x 4" LONG TOE ALUM. NIPPLE	1	5.3	248-14-00-000	BELL AND DISCHARGE PIPE ASSY	1
1.4	R02989	8" CIRCLE LOCK, MALE ITHPM800	1	5.3.1	248-14-00-034	8" EXTENSION PIPE	1
1.5	248-32-00-105	ALUMINUM CONE-8" TO 10" X 2" HIGH	2	5.3.2	R02982	8" RW COUPLER-NARROW	1
1.6	248-34-00-120	10" ALUM DISCH PIPE-SECTION "A"	1	5.4	R02360	8" SQ HUSKY GASKET	2
1.7	248-34-00-121	10" ALUM DISCHARGE PIPE-SECTION "B"	1	5.5	R02484	8" SUCTION HOSE CLAMP	2
				5.6	248-17-00-000	8"ALUMINUM EXT PIPE W/RING ASSY	1
1.8	248-34-00-122	10" ALUM DISCHARGE PIPE-SECTION " C"	1	5.6.1	248-17-00-051	8" ALUMINUM EXTENSION PIPE	1
				5.6.2	R02989	8" CIRCLE LOCK, MALE ITHPM800	1
1.9	248-34-00-123	10" ALUM DISCHARGE PIPE-SECTION "D"	1	5.7	244-09-00-000	8" CLAMP & CHAIN ASSY	1
				5.8	R07823	3/8" FLAT WASHER	1
1.10	248-05-00-036	CHAIN LUG	1	5.9	R07619	3/8 x 1 UNC HEX BOLT	1
1.11	248-05-00-038	STOP LUG	2	5.10	R07794	3/8-16 UNC FLANGE NUT	1
2	248-04-00-000	UPPER PIPE SLIDING CLAMP ASSY	1	6	248-04-01-000	UPPER PIPE SLIDING CLAMP ASSY	1
2.1	248-33-01-113	OUTER FRAME PIVOT BRKT	2	6.1	248-04-01-018	UPPER CLAMP TUBE	1
2.2	248-04-01-000	UPPER PIPE SLIDING CLAMP ASSY	1	6.2	248-04-01-019	UPPER CLAMP BOLT PLATE	2
3	248-03-00-000	LOWER PIPE CLAMP ASSY	1	7	242-00-00-221	CONE CLAMP ON BRKT	1
3.1	242-00-00-221	CONE CLAMP ON BRKT	1	8	248-00-00-070	10"FLEX HOSE FOR TOP OF PIPE CART	1
3.2	248-03-00-050	LOWER CLAMP PIVOT BRKT	2				
4	244-09-00-000	8" CLAMP & CHAIN ASSY	1	9	R02778	3" CAMLOCK M->F NPT	1
4.1	R02488	8" RINGLOCK CLAMP	1	10	R02784	3" F CAMLOCK CAP	1
4.2	250-97-00-297	CLAMP CHAIN	1	11	R07671	7/16 x 1 1/4 UNC HEX BOLT	12
5	248-25-00-000	8" LAYFLAT HOSE W/ENDS KIT	1	12	R07784	7/16-14 UNC HEX NUT	12
5.1	248-06-00-000	8" - 45° ALUMINUM PUMP ELBOW W/RING ASSY	1	13	R07804	7/16" LOCK WASHER	12
				14	R07619	3/8 x 1 UNC HEX BOLT	1
5.1.1	248-24-00-074	ALUMINUM HANDLE	1	15	R02492	10" SUPER CLAMP	1
5.1.2	248-06-00-024	ELBOW PC - A	2	16	R07803	3/8" LOCK WASHER	1
5.1.3	248-06-00-078	ELBOW PC - B	2	17	R07783	3/8-16 UNC HEX NUT	1

# PIPE CART FRAME

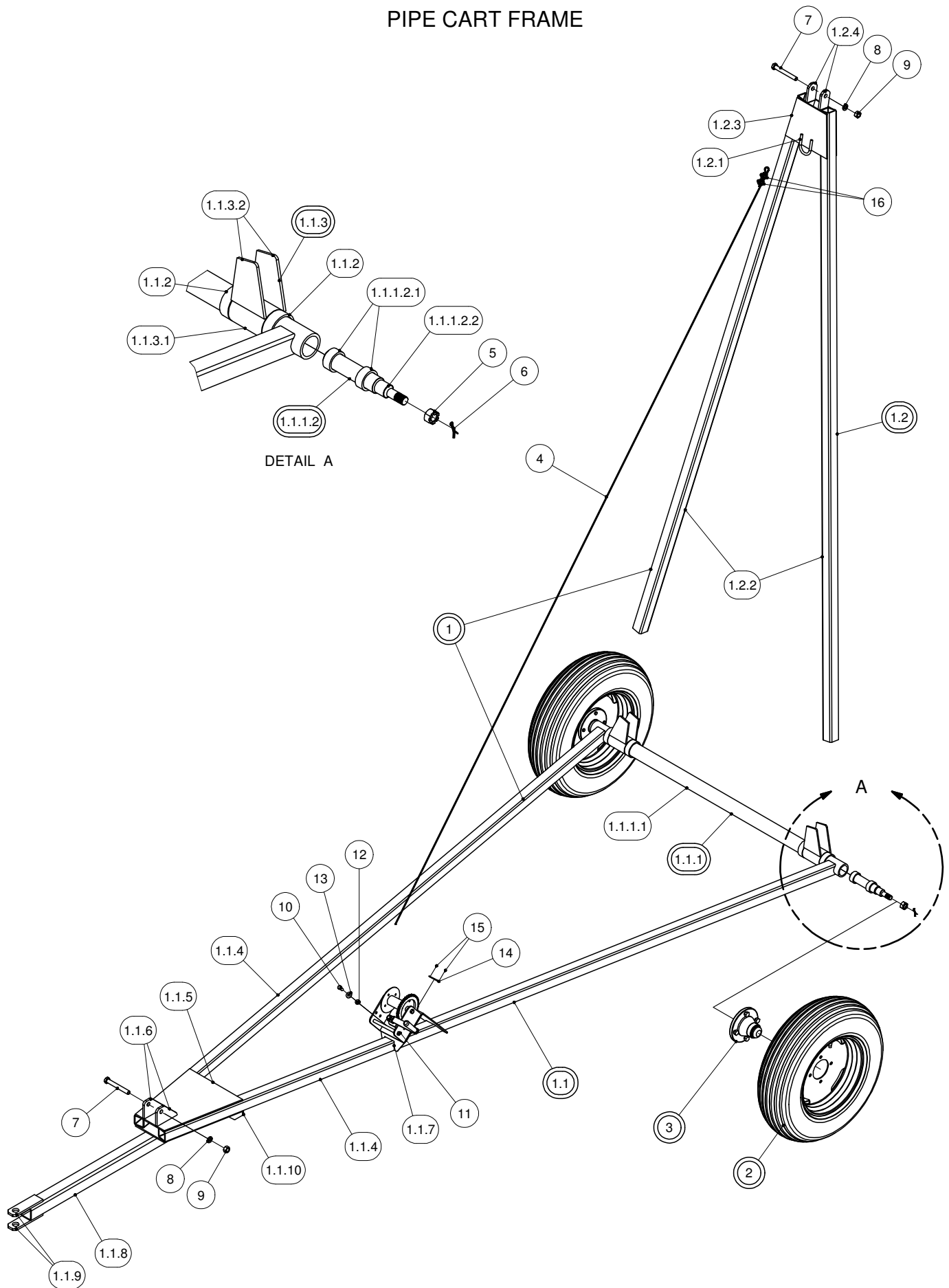

## PIPE CART FRAME

PARTS LIST			
ITEM	PART NUMBER	DESCRIPTION	QTY
1	248-33-00-000	2012 PIPE CART FRAME KIT	1
1.1	248-33-01-000	BASE FRAME ASSY W/ PIVOT ASSY	1
1.1.1	248-01-03-000	AXLE ASSY	1
1.1.1.1	248-01-03-023	AXLE TUBE	1
1.1.1.2	250-64-27-000	SPINDLE ASSY	2
1.1.1.2.1	250-64-27-149	PLUG WASHER	2
1.1.1.2.2	R20141	SPINDLE	1
1.1.2	248-01-00-014	STOP TUBE	4
1.1.3	248-33-02-000	INNER PIVOT ASSY	2
1.1.3.1	248-01-02-009	AXLE MOUNT TUBE	1
1.1.3.2	248-33-02-114	PIVOT SLEEVE STRAP	2
1.1.4	248-33-01-109	OUTER FRAME ARM	2
1.1.5	248-33-01-112	TOP GUSSET	1
1.1.6	248-33-01-113	OUTER FRAME PIVOT BRKT	2
1.1.7	248-01-01-037	WINCH BRKT	1
1.1.8	248-33-01-129	TONGUE TUBE	1
1.1.9	206-02-00-014	TONGE PLATE	2
1.1.10	248-33-01-130	LOWER GUSSET	1
1.2	248-33-03-000	INNER FRAME ASSY	1
1.2.1	248-01-02-012	CABLE BRKT	1
1.2.2	248-33-03-115	INNER FRAME LEG	2
1.2.3	248-33-03-116	INNER FRAME GUSSET	2
1.2.4	248-33-03-117	INNER FRAME PIVOT BRKT	2
2	250-65-00-000	TIRE & WHEEL ASSY - 5.9 x 15	2
3	250-60-30-000	H-411 HUB COMPLETE	2
4	248-00-00-013	LIFT CABLE	1
5	R20142	SLOTTED HEX NUT	2
6	R08002	5/32 x 1 1/2 COTTER PIN	2
7	R07652	5/8 x 5 UNC HEX BOLT	2
8	R07806	5/8" LOCK WASHER	2
9	R07786	5/8-11 UNC HEX NUT	2
10	R07619	3/8 x 1 UNC HEX BOLT	3
11	R10350	1 TON WORM GEAR WINCH	1
12	R07794	3/8-16 UNC FLANGE NUT	3
13	R07823	3/8" FLAT WASHER	3
14	R09071	SERIAL NUMBER PLATE	1
15	R08152	6 x 1/4 PAN HD SOCKET SCREW	2
16	R08077	3/16" CABLE CLAMP	2

## TIRE, WHEEL AND HUB

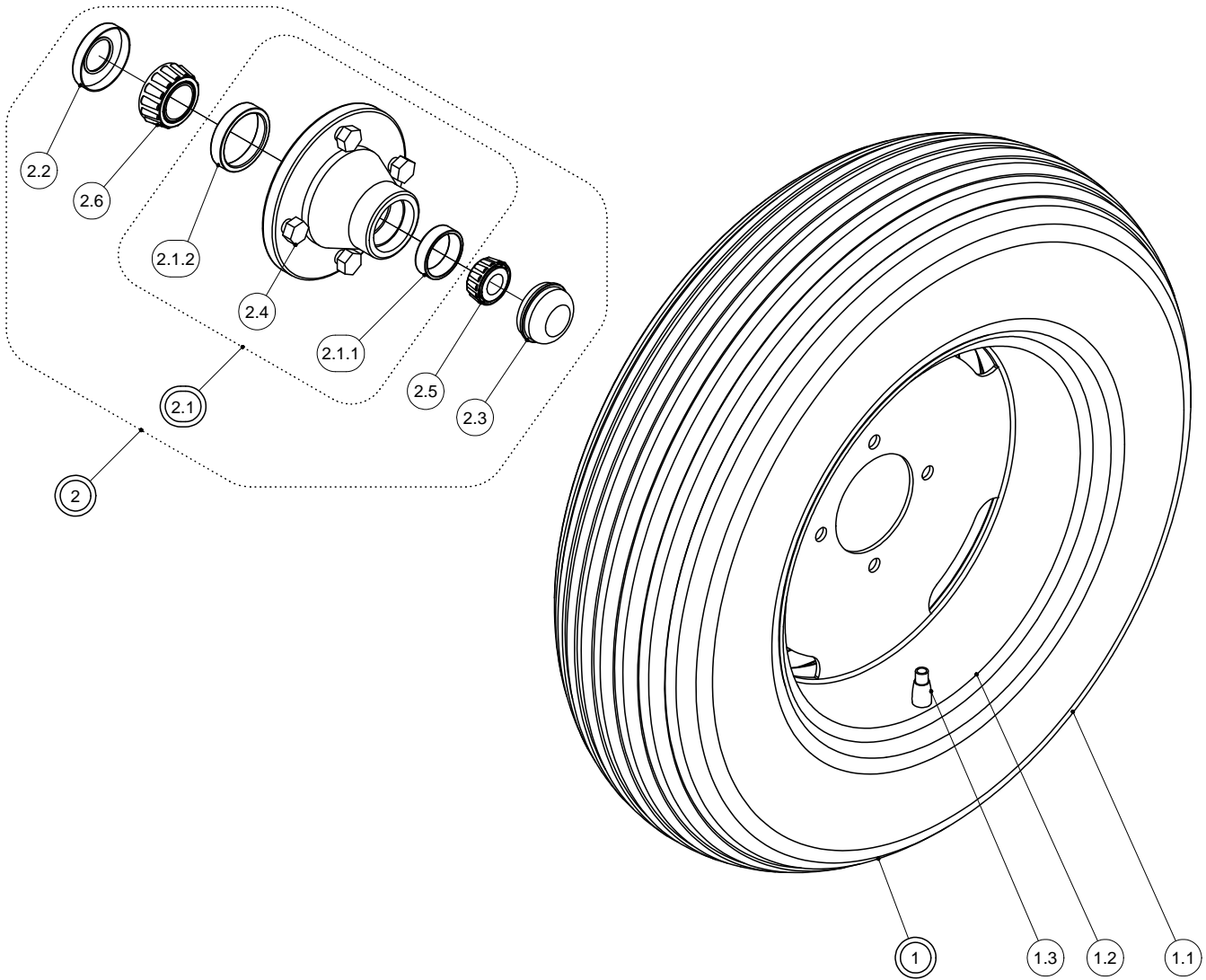

PARTS LIST			
ITEM	PART NUMBER	DESCRIPTION	QTY
1	250-65-00-000	TIRE & WHEEL ASSY - 5.9 x 15	1
1.1	R20016	5.9 x 15 RIB IMPLEMENT TIRE	1
1.2	R20057	4.5 x 15 WHEEL - 4 BOLT	1
1.3	R20020	VALVE STEM	1
2	250-60-30-000	H-411 HUB COMPLETE	1
2.1	R20139	H-411 HUBS w/ CUPS	1
2.1.1	R20130	H411 LM11910 O.CUP	1
2.1.2	R20129	H411 LM67010 I.CUP	1
2.2	R20144	OIL SEAL CRSE11	1
2.3	R20143	DUST CAP	1
2.4	R20145	WB55 1/2 x 1 WHEEL BOLT	4
2.5	R20158	LM11949 OUTER CONE .75" BORE	1
2.6	R20159	LM67048 INNER CONE 1.25" BORE	1



## **GUARANTEE**

All Husky Farm Equipment manufactured by Husky Farm Equipment Limited is guaranteed. Guarantee covers all the replacement cost or repair of all parts said to be defective from manufacture. Guarantee also covers labour installing said parts, if installed at Husky Manufacturing plant. Time and use is the essence of the guarantee. If equipment is used on a private property for an individual's use, guarantee will be in effect for twelve months from date of invoice. If equipment is used for commercial use to do custom work for money then guarantee will be in effect for three months only from date of invoice.

## **EXEMPTIONS FROM GUARANTEE**

Cost of transportation of equipment to or from Husky Farm Equipment Limited either by customer or by Husky's service staff or cost of mail or public transportation is not covered. Tires and electric or hydraulic motors are covered by manufacturer's warranty and although Husky may assist to get warranty, Husky will not be responsible other than that allowed by manufacturer's warranty. Items subject to normal wear from use not covered by guarantee if faulty part is simply worn.