

Date Purchased _____ Machine Serial No. _____

Size of Pump _____ Options _____

The key number system in this parts book is arranged as follows:

- ◎ - Key numbers with two circles denotes main assemblies.
- - Key numbers with one circle are individual parts

Please order parts by number



3" ELECTRIC TRANSFER PUMP

ELECTRIC PUMP – 4ft ▪ 230-00-00-000

ELECTRIC PUMP – 5ft ▪ 232-00-00-000

ELECTRIC PUMP – 6ft ▪ 234-00-00-000

ELECTRIC PUMP – 8ft ▪ 236-00-00-000

ELECTRIC PUMP – 10ft ▪ 238-00-00-000

ELECTRIC PUMP – 12ft ▪ 239-00-00-000

OPERATING INSTRUCTIONS:

1. Pump must turn counter-clockwise when looking down from top.
2. Fasten pump solid so it will not move when operating.
3. Make sure all moving parts are shielded.
4. Keep children and livestock away from pump.
5. Have an Electrician check amp draw when operating to make sure the motor has enough electricity.
6. Check bottom bearing for wear occasionally.
7. Keep belts snug but not overly tight.
8. **EXTREME DANGER** – Never enter a dirty manure spreader or storage tank – one breath of hydrogen sulphide gas is enough to kill. Have a ladder in your pit, so that if by accident you should fall in, you can get out.

3" ELECTRIC MAIN FRAME

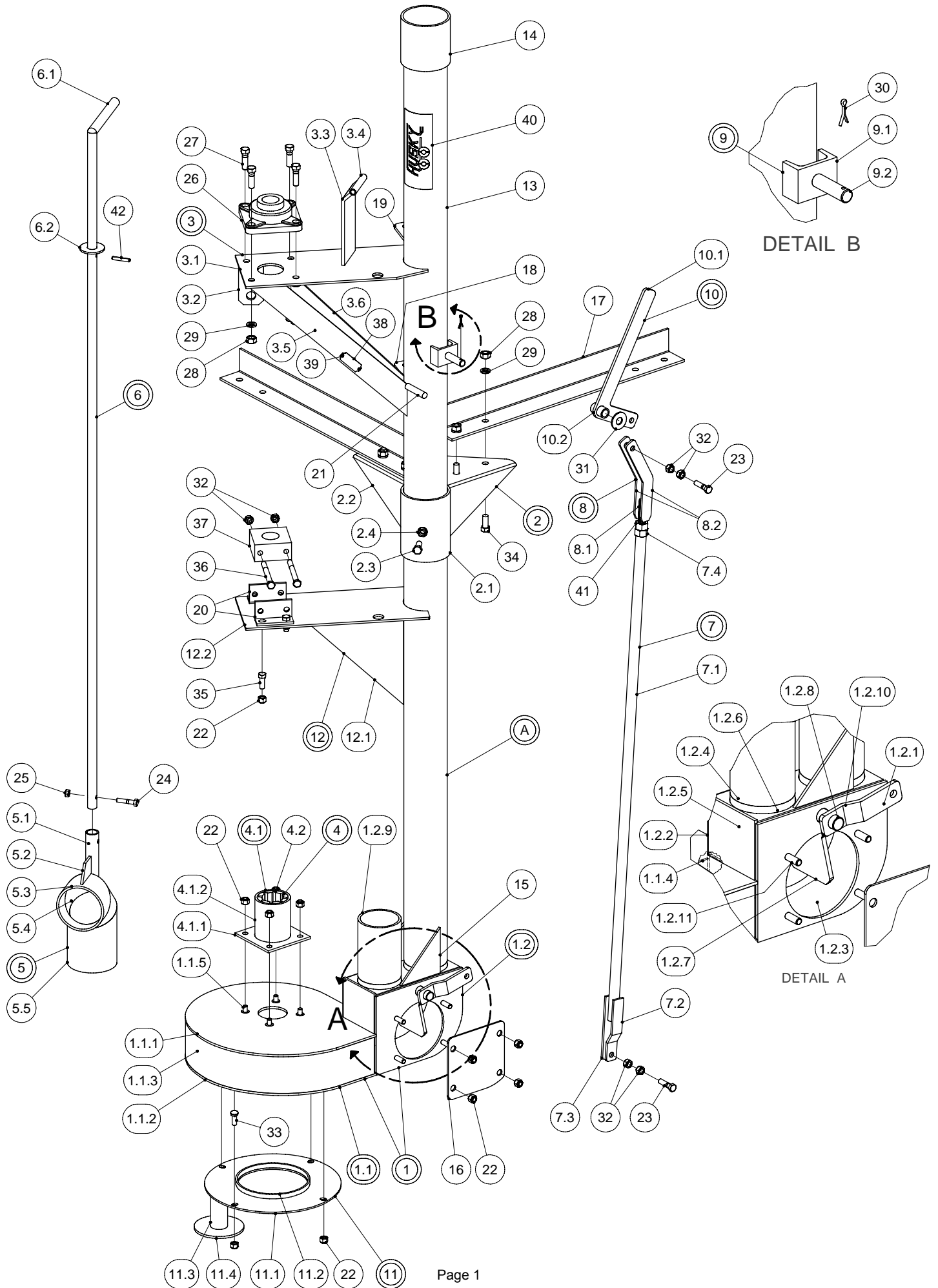

3" ELECTRIC MAIN FRAME

Parts List				Parts List			
ITEM	PART NUMBER	DESCRIPTION	QTY	ITEM	PART NUMBER	DESCRIPTION	QTY
A	239-01-00-000	PUMP HOUSING & STANDPIPE ASSY - 12 FT	1		234-05-00-000	CONTROL ROD ASSY - 6 FT MODEL	1
	238-01-00-000	PUMP HOUSING & STANDPIPE ASSY - 10 FT	1		232-05-00-000	CONTROL ROD ASSY - 5 FT MODEL	1
	236-01-00-000	PUMP HOUSING & STANDPIPE ASSY - 8 FT	1	7	230-05-00-000	CONTROL ROD ASSY - 4 FT MODEL	1
	234-01-00-000	PUMP HOUSING & STANDPIPE ASSY - 6 FT	1	(7.1)	239-05-00-055	CONTROL PIPE - 12 FT MODEL	1
	232-01-00-000	PUMP HOUSING & STANDPIPE ASSY - 5 FT	1		238-05-00-054	CONTROL PIPE - 10 FT MODEL	1
	230-01-00-000	PUMP HOUSING & STANDPIPE ASSY - 4 FT	1		236-05-00-053	CONTROL PIPE - 8 FT MODEL	1
1	230-32-00-000	CHANGE BOX & HOUSING ASSY	1		234-05-00-052	CONTROL PIPE - 6 FT MODEL	1
1.1	230-34-00-000	FAN HOUSING ASSY	1		232-05-00-051	CONTROL PIPE - 5 FT MODEL	1
1.1.1	230-34-00-130	FAN HOUSING TOP PLATE	1	7.1	230-05-00-050	CONTROL PIPE - 4 FT MODEL	1
1.1.2	230-22-00-106	FAN HOUSING BOTTOM PLATE	1	7.2	230-05-00-056	CONTROL ROD BRKT	1
1.1.3	230-01-01-003	HOUSING BAND	1	7.3	230-05-00-057	CONTROL ROD BAR	1
1.1.4	230-22-00-107	FILLER PLATE	1	7.4	R07786	5/8 HEX NUT	1
1.1.5	R08244	3/8 x 3/4 FLAT HEAD SLOT S.S.	4	8	230-13-00-000	OVER CENTER ARM ASSY	1
1.2	230-01-02-000	CHANGE BOX ASSY	1	8.1	230-13-00-076	ADJUSTING ROD	1
1.2.1	230-01-02-006	INSPECTION SIDE PLATE	1	8.2	230-13-00-075	OVER CENTER ARM	2
1.2.2	230-01-02-007	SIDE PLATE	1	9	230-01-07-000	PIVOT PIN ASSY	1
1.2.3	230-01-02-008	CHANGE BOX BAND	1	9.1	230-01-07-031	PIVOT PIN BRKT	1
1.2.4	230-01-02-009	TOP PLATE	1	9.2	230-01-07-030	PIVOT PIN	1
1.2.5	230-01-02-010	END PLATE	1	10	230-04-00-000	AGITATOR HANDLE ASSY	1
1.2.6	230-01-02-011	FLAPPER SEAT	2	10.1	230-04-01-131	HANDLE	1
1.2.7	230-01-02-012	FLAPPER	1	10.2	230-04-00-047	HANDLE PIVOT	1
1.2.8	230-01-02-013	FLAPPER SHAFT	1	11	230-21-00-000	COVER PLATE ASSY	1
1.2.9	230-01-02-118	FLAPPER SEAT LONG	1	11.1	230-21-00-104	HOUSING COVER PLATE	1
1.2.10	230-01-02-005	FLAPPER ARM	1	11.2	230-21-00-105	INLET RING	1
1.2.11	R08323	3/8 x 1 SS WELD STUD	4	11.3	230-06-00-059	FOOT SPACER	1
2	230-11-00-000	FLOOR BRKT ASSY	1	11.4	230-06-00-060	FOOT	1
2.1	230-11-00-072	SLIDE TUBE	1	12	234-01-08-000	INTERMEDIATE BRG PLATE ASSY	1
2.2	230-11-00-140	FLOOR BRKT BASE	1	12.1	234-01-08-116	INTERMEDIATE BRG GUSSET	1
2.3	R07628	7/16 x 1 HEX BOLT	1	12.2	234-01-08-041	INTERMEDIATE BRG PLATE	1
2.4	R07879	7/16 FLANGE NUT	1	(13)	239-01-00-038	STANDPIPE - 12 FT MODEL	1
3	230-01-04-000	UPPER BRG PLATE ASSY	1		238-01-00-037	STANDPIPE - 10 FT MODEL	1
3.1	230-01-04-022	BEARING PLATE	1		236-01-00-036	STANDPIPE - 8 FT MODEL	1
3.2	230-01-04-024	TENSION ROD BRKT	1		234-01-00-035	STANDPIPE - 6 FT MODEL	1
3.3	230-01-04-026	GUARD HINGE PLATE	1		232-01-00-034	STANDPIPE - 5 FT MODEL	1
3.4	230-01-04-027	GUARD SLEEVE	1	13	230-01-00-033	STANDPIPE - 4 FT MODEL	1
3.5	230-01-04-023	RH BRG PLATE BRACE	1	14	230-12-00-074	ADAPTER PIPE	1
3.6	230-01-04-025	LH BRG PLATE BRACE	1	15	230-01-00-040	STANDPIPE GUSSET	2
4	230-33-00-000	BEARING & HOLDER ASSY	1	16	230-00-00-084	INSPECTION PLATE	1
4.1	230-33-09-000	BEARING HOLDER ASSY	1	17	230-00-00-077	FLOOR BRKT LEGS	2
4.1.1	230-33-09-128	BEARING HOLDER BACK PLATE	1	18	230-01-00-139	LOWER MOTOR MOUNT ASSY	1
4.1.2	230-33-09-129	BRG HOLDER	1	19	230-01-00-138	UPPER MOTOR MOUNT ASSY	1
4.2	R20223	URETHANE	1	20	234-00-00-144	BRG HOLDER	2
5	230-24-00-000	AGITATING ELBOW ASSY	1	21	230-01-00-039	STOP ROD	1
5.1	230-01-03-020	TURN SOCKET	1	22	R08247	3/8 NYLOCK NUT	16
5.2	230-01-03-021	TURN SOCKET GUSSET	1	23	R07620	3/8 x 1 1/2 HEX BOLT	2
5.3	230-01-03-017	AGITATING ELBOW BASE	1	24	R07612	5/16 x 1 1/2 HEX BOLT	1
5.4	230-01-03-018	AGITATING ELBOW CENTER PIECE	1	25	R07782	5/16 HEX NUT	1
5.5	230-24-00-117	AGITATING ELBOW TOP PIECE	1	26	R20185	1 3/8 FLANGE BRG	1
(6)	239-30-00-000	AGITATOR TURN LEVER ASSY - 12 FT MODEL	1	27	R07629	7/16 x 1 1/2 HEX BOLT	4
	238-29-00-000	AGITATOR TURN LEVER ASSY - 10 FT MODEL	1	28	R07784	7/16 HEX NUT	8
	236-28-00-000	AGITATOR TURN LEVER ASSY - 8 FT MODEL	1	29	R07804	7/16 LOCK WASHER	8
	234-27-00-000	AGITATOR TURN LEVER ASSY - 6 FT MODEL	1	30	R08021	1/8 x 1 S.S. COTTER PIN	1
	232-26-00-000	AGITATOR TURN LEVER ASSY - 5 FT MODEL	1	31	R07852	9/16 FLAT WASHER	1
6	230-25-00-000	AGITATOR TURN LEVER ASSY - 4 FT MODEL	1	32	R07783	3/8 HEX NUT	6
	239-30-00-124	AGITATOR TURN LEVER - 12 FT MODEL	1	33	R07721	3/8 x 1 CARRIAGE BOLT	4
	238-29-00-123	AGITATOR TURN LEVER - 10 FT MODEL	1	34	R07628	7/16 x 1 HEX BOLT	4
	236-28-00-122	AGITATOR TURN LEVER - 8 FT MODEL	1	35	R07619	3/8 x 1 HEX BOLT	4
	234-27-00-121	AGITATOR TURN LEVER - 6 FT MODEL	1	36	R07625	3/8 x 4 HEX BOLT	2
	232-26-00-120	AGITATOR TURN LEVER - 5 FT MODEL	1	37	R20229	1 3/8 WOOD BRG	1
6.1	230-25-00-119	AGITATOR TURN LEVER - 4 FT MODEL	1	38	R09071	SERIAL NUMBER PLATE	1
6.2	R07827	3/4" FLAT WASHER	1	39	R08152	6 x 1/4 PAN HD SOCKET SCREW	2
(7)	239-05-00-000	CONTROL ROD ASSY - 12 FT MODEL	1	40	R09671	"HUSKY" DECAL	1
	238-05-00-000	CONTROL ROD ASSY - 10 FT MODEL	1	41	R07786	5/8 HEX NUT	1
	236-05-00-000	CONTROL ROD ASSY - 8 FT MODEL	1	42	R07962	1/4 x 1 1/2 ROLL PIN	1

IMPELLER & SHAFT

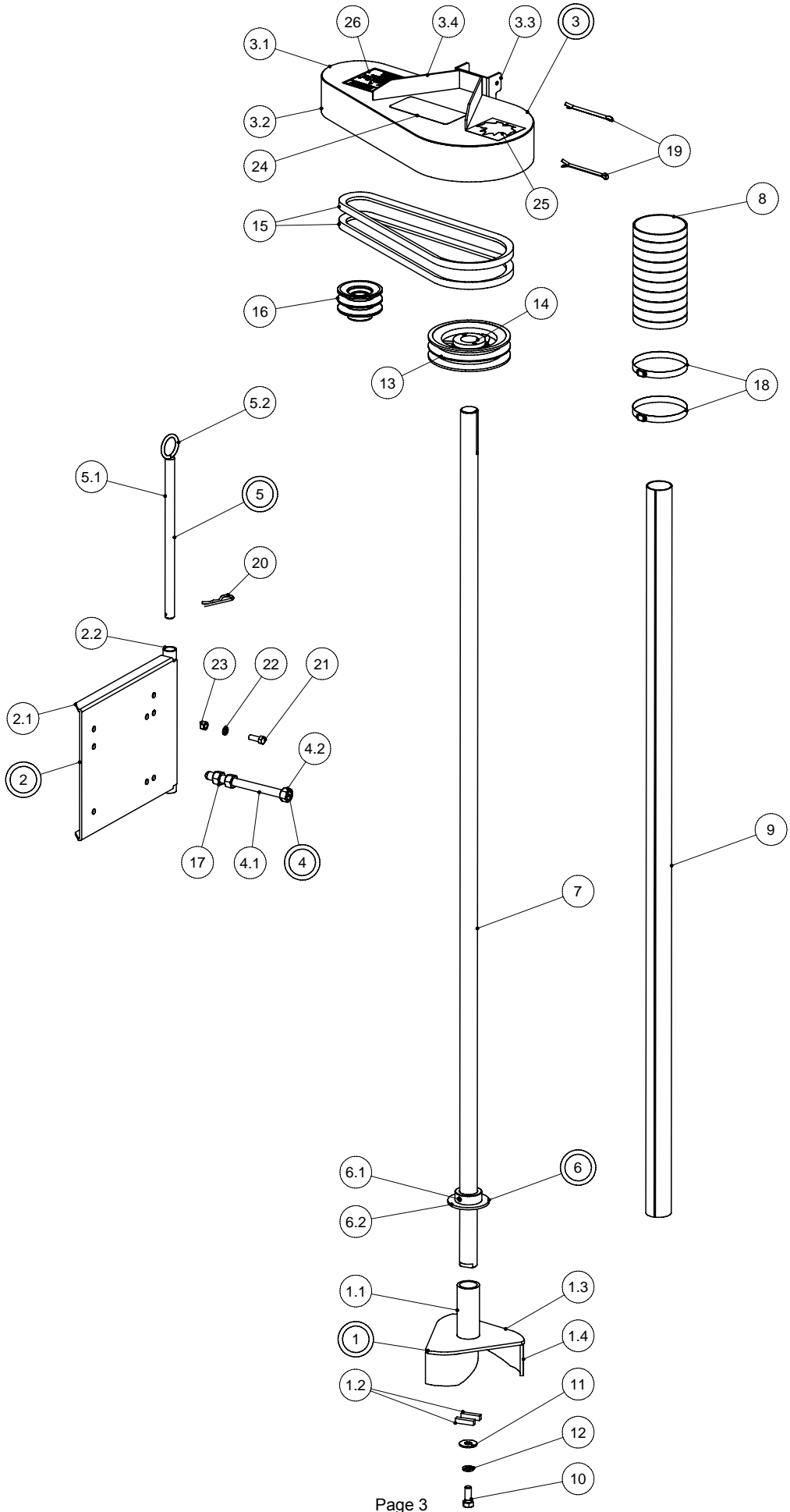

IMPELLER & SHAFT

PARTS LIST			
ITEM	PART NUMBER	DESCRIPTION	QTY
1	230-31-00-000	IMPELLER ASSY - CHT	1
1.1	230-31-00-099	SHAFT SLEEVE	1
1.2	230-31-00-103	SHAFT SLEEVE PIN	2
1.3	230-31-00-127	IMPELLER BACK PLATE	1
1.4	230-31-00-126	IMPELLER BLADE - CHT	3
2	230-07-00-000	MOTOR MOUNT ASSY	1
2.1	230-07-00-062	MOTOR MOUNT	1
2.2	230-07-00-061	MOTOR MOUNT SLEEVE	1
3	230-10-00-000	BELT GUARD ASSY	1
3.1	230-10-00-066	GUARD TOP	1
3.2	230-10-00-068	GUARD BAND	1
3.3	230-10-00-141	GUARD SUPPORT CHANNEL	1
3.4	230-10-00-142	GUARD BRACE	1
4	230-09-00-000	TENSION BOLT ASSY	1
4.1	230-09-00-065	TENSION ROD	1
4.2	R07786	5/8 HEX NUT	1
5	230-08-00-000	MOTOR MOUNT PIN ASSY	1
5.1	230-08-00-064	MOTOR MOUNT PIN	1
5.2	250-00-00-354	1/4 X 1 1/2" RING	1
6	230-23-00-000	SPLASH GUARD ASSY	1
6.1	R09554	1 3/8" LOCK COLLAR	1
6.2	R07848	1 3/8 FLAT WASHER	1
(7)	239-00-00-114	DRIVE SHAFT - 12 FT MODEL	1
	238-00-00-113	DRIVE SHAFT - 10 FT MODEL	1
	236-00-00-112	DRIVE SHAFT - 8 FT MODEL	1
	234-00-00-111	DRIVE SHAFT - 6 FT MODEL	1
	232-00-00-110	DRIVE SHAFT - 5 FT MODEL	1
7	230-00-00-109	DRIVE SHAFT - 4 FT MODEL	1
8	230-00-00-093	4" FLEX HOSE	1
(9)	239-00-00-137	SHAFT GUARD - 12 FT MODEL	2
	238-00-00-136	SHAFT GUARD - 10 FT MODEL	1
	236-00-00-135	SHAFT GUARD - 8 FT MODEL	1
	234-00-00-134	SHAFT GUARD - 6 FT MODEL	1
	232-00-00-133	SHAFT GUARD - 5 FT MODEL	1
9	230-00-00-132	SHAFT GUARD - 4 FT MODEL	1
10	R08217	1/2 x 1 1/4 SS HEX BOLT	1
11	R07825	1/2 FLAT WASHER	1
12	R07805	1/2 LOCK WASHER	1
13	R21062	2 HB x 6.4 SHEEVE w/ BUSHING - 1 3/8 BORE	1
14	R21052	PULLEY BUSHING - 1 3/8	1
15	R20932	38B - V BELTS	2
16	R21064	2 HB x 3.5 x 1 1/8 BORE PULLEY	1
17	R07786	5/8 HEX NUT	2
18	R02237	H-5 72 GEAR CLAMP 4 1/2"	2
19	R08017	1/4 x 4 COTTER PIN	2
20	R07948	5/32 HAIR PIN	1
21	R07619	3/8 x 1 HEX BOLT	1
22	R07803	3/8 LOCK WASHER	1
23	R07783	3/8 HEX NUT	1
24	R09692	"CAUTION" - "ROTATING CCW" DECAL	1
25	R09508	"MADE IN CANADA" DECAL - LARGE	1
26	R21521	"ROTATING DRIVE LINE" DECAL	1

3" CHT HOUSING & COVERPLATE KIT

PARTS LIST			
ITEM	PART NUMBER	DESCRIPTION	QTY
1	230-35-04-000	CHT HOUSING & CHANGE BOX ASSY	1
1.1	230-35-01-000	CHT CHANGE BOX ASSY	1
1.1.1	230-01-02-006	INSPECTION SIDE PLATE	1
1.1.2	230-01-02-007	SIDE PLATE	1
1.1.3	230-35-01-145	CHANGE BOX BAND	1
1.1.4	230-01-02-009	TOP PLATE	1
1.1.5	230-01-02-011	FLAPPER SEAT	2
1.1.6	230-35-01-146	FLAPPER	1
1.1.7	230-01-02-013	FLAPPER SHAFT	1
1.1.8	230-01-02-118	FLAPPER SEAT LONG	1
1.1.9	230-01-02-005	FLAPPER ARM	1
1.1.10	R08323	3/8 x 1 SS WELD STUD	4
1.2	230-35-02-000	CHT FAN HOUSING ASSY-3"	1
1.2.1	230-35-02-149	CHT HOUSING BAND	1
1.2.2	R08244	3/8 x 3/4 FLAT HEAD SLOT S.S.	4
1.2.3	230-35-02-148	FAN HOUSING BOTTOM PLATE	1
1.2.4	230-35-02-147	CHT FAN HOUSING TOP PLATE	1
1.3	230-01-02-010	END PLATE	1
2	230-35-03-000	CHT COVER PLATE ASSY	1
2.1	230-35-03-151	CHT COVER PLATE	1
2.2	230-35-03-152	CHT INLET RING	1
2.3	230-06-00-059	FOOT SPACER	1
2.4	230-06-00-060	FOOT	1
3	R07794	3/8 FLANGE NUT	4
4	R07721	3/8 x 1 CARRIAGE BOLT	4

3" CHT HOUSING & COVERPLATE KIT 230-35-00-000

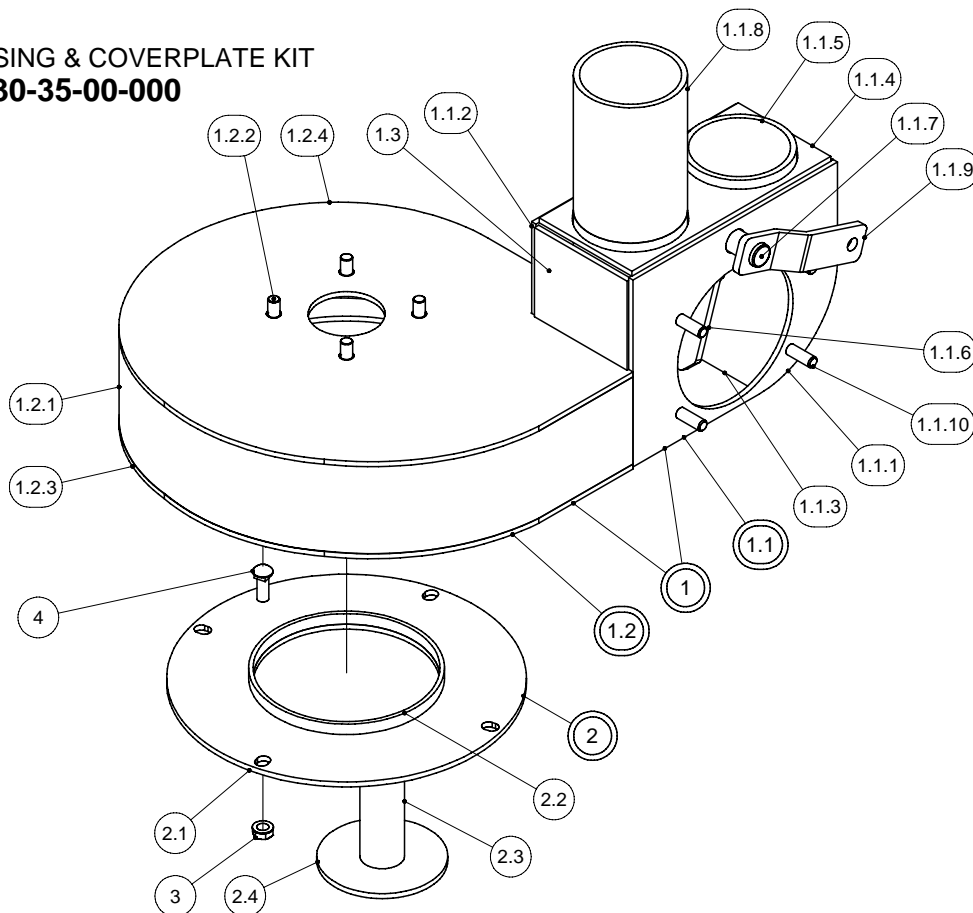

ELECTRIC CUTTER BLADE KIT

PARTS LIST			
ITEM	PART NUMBER	DESCRIPTION	QTY
1	260-13-08-000	CUTTER BLADE ASSY	1
1.1	260-13-08-037	CUTTER BLADE TUBE	1
1.2	260-13-08-036	CUTTER BLADE	2
1.3	260-13-08-040	STOP BAR	1
1.4	260-13-08-038	PLUG WASHER	1
2	550-19-00-000	COVER PLATE ASSY W/LEDGER	1
2.1	230-06-00-059	FOOT SPACER	1
2.2	550-19-00-061	COVER PLATE W/LEDGER PLATE	1
2.3	550-19-00-083	COVER PLATE RING	1
2.4	230-06-00-060	FOOT	1
3	R08416	1/2 x 1 1/2 S.S. HEX BOLT	1
4	R07805	1/2 LOCK WASHER	1

ELECTRIC CUTTER BLADE KIT 260-13-00-000

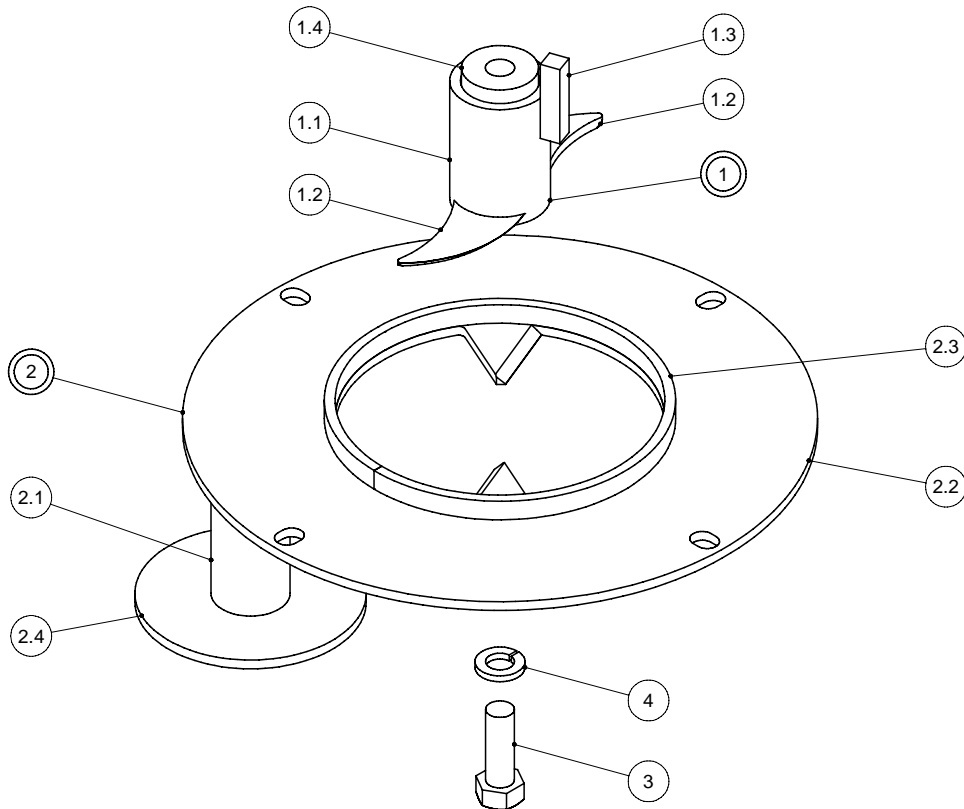

GUARANTEE

All Husky Farm Equipment manufactured by Husky Farm Equipment Limited is guaranteed. Guarantee covers all the replacement cost or repair of all parts said to be defective from manufacture. Guarantee also covers labour installing said parts, if installed at Husky Manufacturing plant. Time and use is the essence of the guarantee. If equipment is used on a private property for an individual's use, guarantee will be in effect for twelve months from date of invoice. If equipment is used for commercial use to do custom work for money then guarantee will be in effect for three months only from date of invoice.

EXEMPTIONS FROM GUARANTEE

Cost of transportation of equipment to or from Husky Farm Equipment Limited either by customer or by Husky's service staff or cost of mail or public transportation is not covered. Tires and electric or hydraulic motors are covered by manufacturer's warranty and although Husky may assist to get warranty, Husky will not be responsible other than that allowed by manufacturer's warranty. Items subject to normal wear from use not covered by guarantee if faulty part is simply worn.