

Date Purchased _____ Machine Serial No. _____

Size of Spreader _____ Options _____

The key number system in this parts book is arranged as follows:

- ⊙ - Key numbers with two circles denotes main assemblies.
- - Key numbers with one circle are individual parts

Please order parts by number



18000L ELITE SPREADER ▪ 358-00-00-000

OPERATING INSTRUCTIONS:

1. Heed all warnings.
2. Minimum HP requirements to safely operate on level terrain, on hilly terrain HP should be increased.

4500L	70 HP
7000L	85 HP
9000L	95 HP
12000L	110 HP
14000L	130 HP
15000L	140 HP
18000L	160 HP
23000L	200 HP
28000L	250 HP

3. If machine is equipped with hydraulic brakes that are operated from the tractor hydraulics, they will not work should the tractor motor stop. Inspect brakes before each use. Brakes must be bled before initial use unless installed at factory. When releasing brakes the tractor hydraulic lever must be put in the opposing position to release pressure. Do not put in float position they will not release.
4. Tractor PTO spline must be approximately 14" (355mm) from end of compressed PTO for proper adjustment
5. Hitch tanker to tractor with minimum 1 1/8" (29mm) hardened hitch pin with a safety lock. Use 12,000 Lbs safety chain from spreader to tractor.
6. Do not use tongue stand to support loaded spreader. Put jack in storage position before using.
7. When hooking PTO to tractor make sure motor is stopped. Make sure QD (Quick Disconnect) safety locking pin is in locked position before using.
8. Clean off hose ends before plugging into tractor hydraulics. If spreader is equipped with hydraulic drive on spreading attachment, make sure tractor has sufficient oil flow and pressure to maintain satisfactory spread pattern, if not use another tractor.

This Page is Intentionally Left Blank

OPERATING INSTRUCTIONS continued:

9. After using spreader in freezing conditions make sure impeller housing is drained.
10. Wash tank inside and out each time work is finished. This will increase the life of the tank by many years. See item 6 of Safety instructions
11. Do not drive on public roads after dusk unless equipped with lights required by Department of Transportation in your area.
12. Remove wheels annually and grease wheel bearings.
13. Because manure smells, many farmers have made unfriendly neighbours. If in a residential area a manure injector is a recommended option to bury the smell.
14. Much of the fertilizer value of manure is lost when exposed to air. Getting the manure covered quickly is a very important part of spreading manure.
15. If rustproof coating on interior shows signs of deterioration, have interior repainted. This can be done with a roller or brush. This helps to increase the life of your spreader. It is a valuable maintenance procedure.

SAFETY INSTRUCTIONS:

Do not operate this machine until you fully understand the safe operating practices.

1. Make sure all moving parts are shielded to prevent coming in contact with loose clothing.
2. Keep children clear; do not let children or any person(s) ride the spreader at anytime.
3. Do not support loaded spreader on tongue jack.
4. Keep tire pressure to recommended pressure at all times. Recommended tire pressure being:

Size	Description	PSI	KPA
40 x 14	Airplane Tires	55	379
44 x 16	Airplane Tires	55	379
47 x 18 x 18	Airplane Tires	55	379
50 x 20 x 20	Airplane Tires	55	379
16.5L x 16.1	Implement Tires	35	241
21.5L x 16.1	Implement Tires	35	241
18.4L x 26	Turf Tires	30	207
23.1L x 26	Turf Tires	24	166
28L x 26	Turf Tires	24	166
30.5L x 32	Turf Tires	35-40	241
35.5L x 32	20 ply Turf Tires	35	241
18L x 22.5	Truck Tires	65	448
23.5L x 25	Loader Dozer Tires	55	379

5. Keep wheel bolts torqued to the recommended torque at all times. (Check Daily)

Wheel Bolt Size	Ft/Lbs Torque (Dry)	Ft/Lbs. - Oiled	Meter/Kg - Torque Dry	Meter/Kg - Oiled
9/16 – 18 NF GR. 5	120	90	16.59	12.44
5/8 – 18 NF GR. 8	240	180	33.18	24.89
3/4 – 16 NF GR. 8	420	310	58.07	42.86

6. Never enter a tanker without special breathing equipment to supply oxygen. Manure gases can kill instantly. One breath of Hydrogen Sulphide can kill.
7. When repairing hydraulic hoses, always relieve pressure in hose. Always wear safety glasses while working on spreader.
8. Caution – disc brakes will not release until valve lever is held momentarily in opposite position. This will relieve pressure in brake line. Do not put in float position, they will not release. (Rule does not apply to Husky Manure Spreaders equipped with a Knott Brake System)

18000L TANK COMPLETE

PARTS LIST			
ITEM	PART NUMBER	DESCRIPTION	QTY
1	358-31-00-000	18000L TANK & SILL ASSY	1
2	358-17-00-000	18000L AXLE KIT FOR 28L & 30.5 TIRES	1
3	330-04-00-000	28L x 26 TIRE & WHEEL ASSY	4
4	384-51-00-000	1000 FAN & HOUSING COMPLETE-TAPERED SHAFT	1
5	358-12-00-000	6" DISCHARGE PIPE KIT- 18000L STD	1
6	357-30-00-000	TAIL LIGHT KIT	1
7	340-62-00-000	INDICATOR KIT	1
7.1	340-00-00-536	FLAG SPRING HOLDER	1
7.2	R08037	SPRING FOR SPREADER FLAG	1
7.3	340-62-00-553	INDICATOR HOSE	1
7.4	R07906	5/16-18 UNC x 0.31 SET SCREW - ZINC	1
8	357-29-00-000	ELITE & 18L SL TONGUE & HITCH KIT	1
9	357-63-00-000	SAFETY BAR ASSY	1
10	330-00-00-559	ACCESS TUBE COVER PLATE	1
11	R09071	SERIAL NUMBER PLATE	1
12	R08152	#6 x 1/4" PAN HD SOCKET SCREW	2
13	R09510	"HUSKY" DECAL	2
14	R09511	ACCENT STRIP	2
15	R09783	"CAUTION" DECAL	1
16	R09512	CAPACITY DECAL	1
17	R09672	CAUTION PTO LENGTH DECAL	1
18	R09730	TORQUE, TIRE PRESSURE DECAL	1
19	R09509	"MADE IN CANADA" DECAL - LARGE	1
20	R10097	AMBER REFLECTOR	1
21	R10096	RED REFLECTOR	2
22	R09501	SLOW MOVING VEHICLE DECAL	1
23	R10334	TOXIC GAS PICTORIAL DECAL	1
24	R10335	MANURE SPILL DECAL	1
25	R07619	3/8-16 UNC x 1 HEX BOLT GR.5	6
26	R07794	3/8-16 UNC FLANGE NUT - ZINC	6
27	R07795	1/2-13 UNC FLANGE NUT - ZINC	16
28	R07674	1/2-13 UNC x 1.25 HEX BOLT GR.5	16

18000L TANK ASSY

PARTS LIST				PARTS LIST			
ITEM	PART NUMBER	DESCRIPTION	QTY	ITEM	PART NUMBER	DESCRIPTION	QTY
1	340-01-01-000	18000 L TANK ASSY	1	7.2	384-40-00-492	ACCESS HOLE COVER PLATE	1
1.1	340-01-08-000	18000L BAFFLE ASSY	2	7.3	R07671	7/16-14 UNC x 1.25 HEX BOLT GR.5	16
1.1.1	340-01-01-302	FLANGED TANK BAFFLE	1	7.4	R07879	7/16-14 UNC FLANGE NUT - ZINC	16
1.1.2	340-01-08-561	18000L BAFFLE SUPPORT TUBE	2	8	364-82-00-000	FLANGED TANK OUTLET	1
1.2	340-01-01-301	TANK SHELL	3	8.1	364-81-02-393	HOUSING FLANGE	1
1.3	340-01-01-300	FLANGED TANK END	2	8.2	364-82-00-395	LH OUTLET SIDE PC	1
1.4	340-01-01-559	OVAL REINFORCING PLATE	4	8.3	364-82-00-396	RH OUTLET SIDE PC	1
2	357-60-00-000	CROSS MEMBER ASSY	1	8.4	364-01-03-104	OUTLET TOP PC	1
3	340-01-02-000	R.H. SILL ASSY	1	8.5	364-01-03-105	OUTLET BOTTOM PC	1
3.1	340-01-02-303	18000 L SILL	1	9	340-01-00-546	LIFT HOOK REINFORCING PLATE	3
3.2	340-01-02-304	SILL REINFORCING	1	10	300-01-00-012	TANK LIFT HOOK	2
3.3	340-01-02-305	SILL STIFFENERS	4	11	340-01-00-555	CENTER LIFT HOOK	1
4	340-01-03-000	L.H. SILL ASSY	1	12	340-01-06-312	TANK END STIFFENER	2
5	357-30-03-000	MOUNT BRKT ASSY	2	13	340-01-06-464	TANK STIFFENER CAP	4
6	330-20-03-000	ACCESS TUBE ASSY	1	14	340-01-06-311	SILL CAP	4
6.1	330-20-03-560	ACCESS TUBE FLANGE	1	15	364-02-00-280	AXLE ADJUSTMENT ANGLE	2
6.2	330-20-03-556	ACCESS TUBE	1	16	364-02-00-006	24" MANHOLE	1
7	384-40-00-000	ACCESS HOLE & COVER PLATE KIT	1	17	340-01-00-498	SERIAL NO. BACK PLATE	1
7.1	384-40-01-000	ACCESS RING ASSY	1	18	315-30-00-108	HYD. HOSE HOOK	1
7.1.1	384-40-01-490	ACCESS HOLE FLANGE	1	19	364-95-00-000	LADDER ASSY	1
7.1.2	384-40-01-491	ACCESS HOLE RING	1	20	384-01-00-246	INSIDE CROSS SUPPORT CHANNEL	1

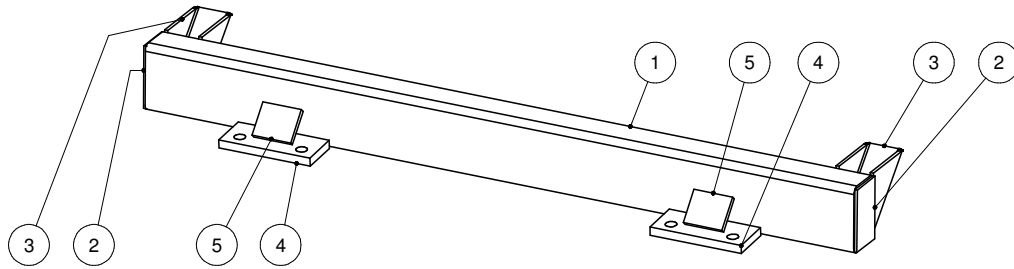

**CROSS MEMBER ASSY
357-60-00-000**

PARTS LIST			
ITEM	PART NUMBER	DESCRIPTION	QTY
1	357-60-00-290	CROSS MEMBER	1
2	357-60-00-291	END CAP	2
3	357-60-00-292	DOUBLE GUSSET	2
4	357-28-00-168	TONGUE STRAP	2
5	364-02-17-123	TONGUE STRAP GUSSET	2

18000L THRU 28000L TONGUE & HITCH KIT

18000L THRU 28000L
TONGUE & HITCH KIT
357-29-00-000

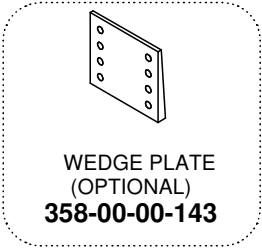
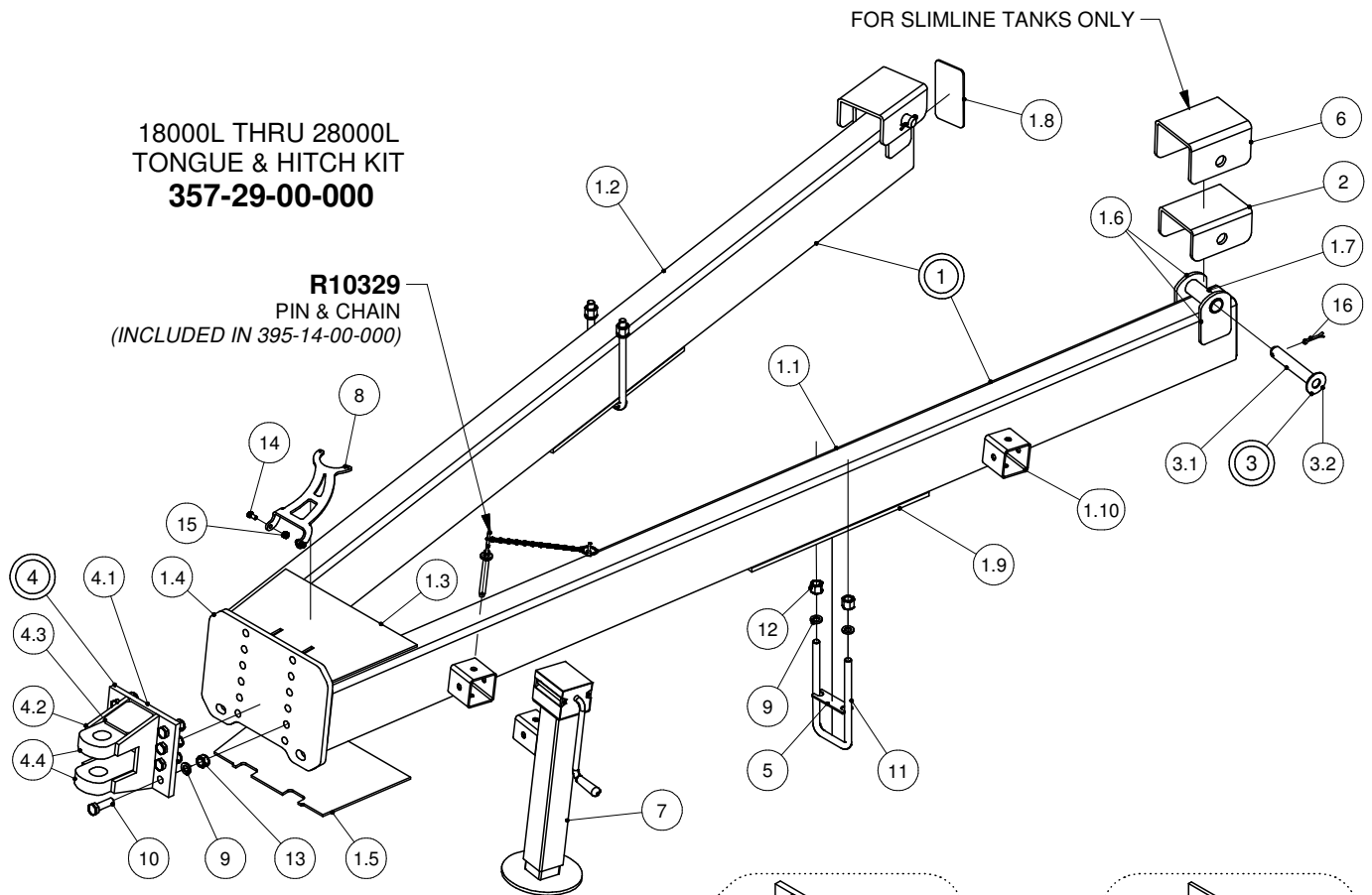

PARTS LIST				PARTS LIST			
ITEM	PART NUMBER	DESCRIPTION	QTY	ITEM	PART NUMBER	DESCRIPTION	QTY
1	357-27-00-000	ELITE & 18000L SL TONGUE ASSY	1	4.1	358-43-00-139	HITCH BACK PLATE	1
1.1	357-27-00-165	LH TONGUE TUBE	1	4.2	358-43-00-141	HITCH SIDE GUSSET	2
1.2	357-27-00-164	RH TONGUE TUBE	1	4.3	358-43-00-142	HITCH UPPER GUSSET	2
1.3	357-27-00-166	UPPER TONGUE TUBE GUSSET	1	4.4	408-04-00-011	HITCH PLATE	2
1.4	358-42-00-137	HITCH BOLT PLATE	1	5	364-00-00-131	U - BOLT SPACER	2
1.5	357-27-00-310	LOWER TONGUE TUBE GUSSET	1	6	394-03-00-014	TONGUE "U" PC - SLIMLINE	2
1.6	315-36-00-146	TONGUE SIDE PC	4	7	395-14-00-000	8000 Lb TONGUE JACK w/SQ TUBE & PIN	1
1.7	315-36-00-145	TONGUE BUSHING	2	8	395-07-00-076	PTO HOLDER BRACKET	1
1.8	315-36-00-147	TONGUE TUBE COVER	2	9	R07807	3/4 LOCK WASHER - ZINC	12
1.9	357-00-00-129	TONGUE REINFORCING PLATE	2	10	R07655	3/4-10 UNC x 2.5 HEX BOLT GR.5	8
1.10	395-07-01-059	TONGUE JACK OUTER BRKLT	2	11	R08172	3/4" UNF x 10" - "U" BOLT	2
2	315-31-00-115	TONGUE "U" PC - ELITE	2	12	R07820	3/4-16 UNF HIGH HEX NUT - GR.8	4
3	315-39-00-000	LOCK PIN ASSY	2	13	R07787	3/4-10 UNC HEX NUT - ZINC	8
3.1	315-39-00-155	TONGUE LOCK PIN	1	14	R07688	3/8-16 UNC x 0.75 HEX BOLT GR.5	2
3.2	R07828	1 FLAT WASHER STD - ZINC	1	15	R07886	3/8-16 UNC 2-WAY LOCK NUT - ZINC	2
4	408-04-00-000	HD CLEVIS HITCH ASSY-1 3/4" HOLE	1	16	R08016	1/4 x 2 COTTER PIN - SS	2

18000L TIRES

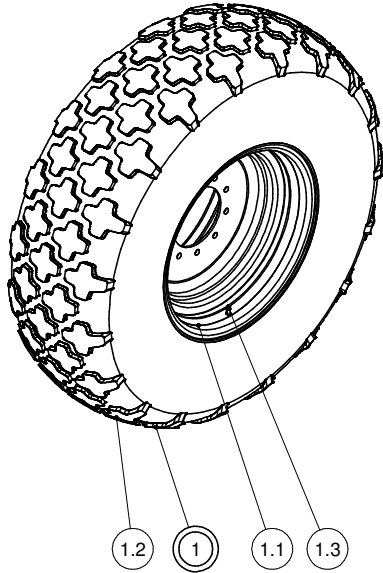

**18.4L x 26 TIRE & WHEEL ASSY
340-68-00-000**

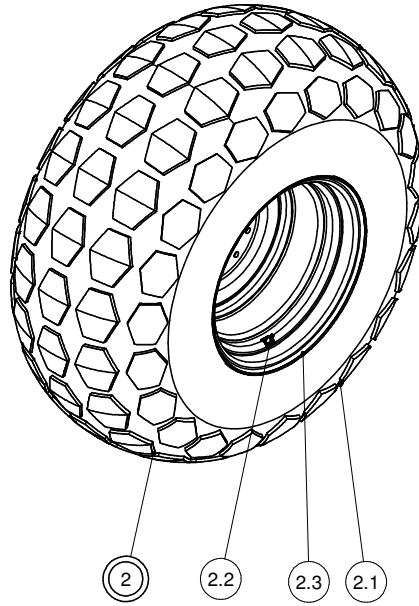

**28L x 26 TIRE & WHEEL ASSY
330-04-00-000**

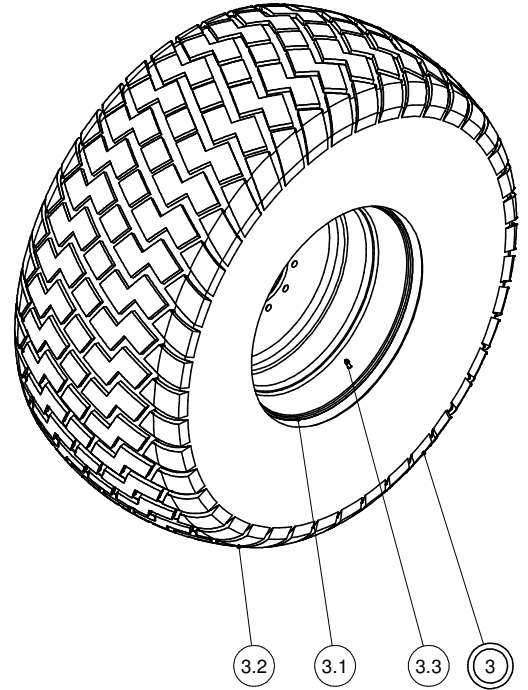

**30.5 RADIAL TIRE & WHEEL ASSY
358-19-00-000**

PARTS LIST			
ITEM	PART NUMBER	DESCRIPTION	QTY
1	340-68-00-000	18.4 X 26 TIRE & WHEEL ASSY	1
1.1	R20075	16" x 26" 10 BOLT WHEEL	1
1.2	R20100	18.4" x 26" 10 PLY TBLS TIRE	1
1.3	R20161	VALVE STEM	1
2	330-04-00-000	28L x 26 TIRE & WHEEL ASSY	1
2.1	R20015	28L x 26 TURF TIRE	1
2.2	R20161	VALVE STEM	1
2.3	R20040	26xDW25B 10-Bolt Wheel 11.25 B.C.	1
3	358-19-00-000	TIRE & WHEEL ASSY - 750/60Rx30.5	1
3.1	R22568	30.5 x 24 10 BOLT WHEEL	1
3.2	R22567	750/60R x 30.5 X 32 ALLIANCE TIRE	1
3.3	R20161	VALVE STEM	1

18000L AXLE KIT

18000L AXLE KIT
358-17-00-000

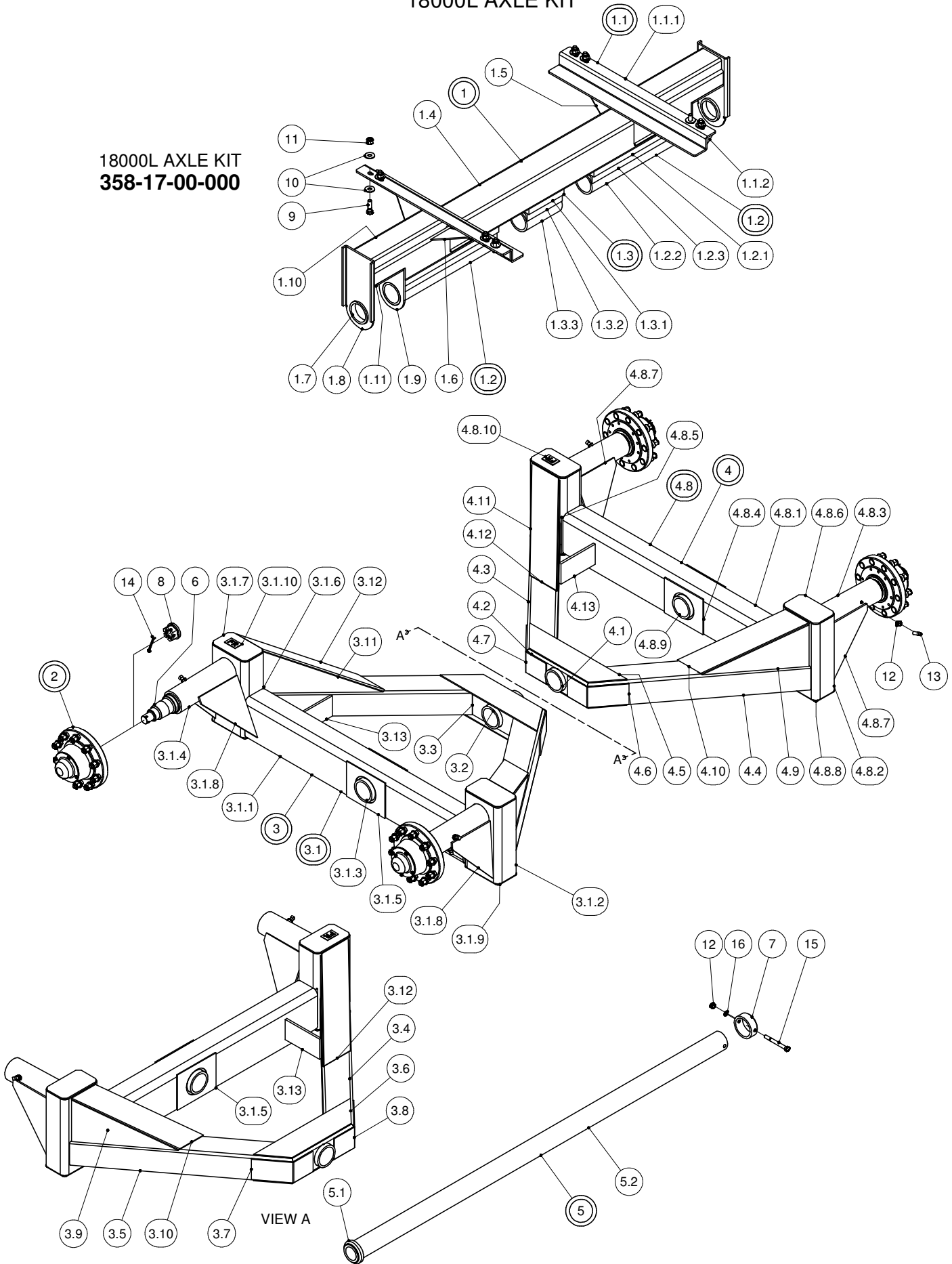

18000L AXLE KIT

PARTS LIST				PARTS LIST			
ITEM	PART NUMBER	DESCRIPTION	QTY	ITEM	PART NUMBER	DESCRIPTION	QTY
1	358-17-03-000	BASE FRAME ASSY	1	3.11	358-17-06-519	FRONT ARM GUSSET	2
1.1	330-69-01-000	SILL "Z" PLATE ASSY	2	3.12	358-17-06-520	FRONT ARM CAP	1
1.1.1	358-85-00-253	SILL "Z" PLATE	1	3.13	358-17-06-521	CORNER GUSSET	2
1.1.2	330-69-00-550	GUSSET	2	4	358-17-08-000	RH TANDEM SIDE ASSY	1
1.2	358-17-04-000	OUTER SLEEVE ASSY	2	4.1	358-83-01-235	WALKER SLEEVE	1
1.2.1	358-17-04-486	CENTER SPACER BAR	1	4.2	358-17-06-511	CENTER CONNECTOR TUBE	1
1.2.2	358-17-04-488	CENTER SLEEVE	1	4.3	358-17-06-512	FRONT TANDEM ARM	1
1.2.3	358-17-04-487	LONG SPACER CHANNEL	1	4.4	358-17-06-513	REAR TANDEM ARM	1
1.3	358-09-02-000	OUTER SLEEVE ASSY	1	4.5	358-17-06-514	REINFORCING PLATE	2
1.3.1	358-85-00-251	SPACER BAR	1	4.6	358-17-06-515	TIE PLATE REAR	1
1.3.2	340-07-08-323	5" CHANNEL @ 9LB	1	4.7	358-17-06-516	TIE PLATE-FRONT	1
1.3.3	340-07-08-322	STATIONARY SLEEVE	1	4.8	358-17-09-000	RH WALKING BEAM ASSY	1
1.4	358-17-03-484	CROSS AXLE SUPPORT	1	4.8.1	358-17-07-510	WALKING BEAM	1
1.5	340-07-00-330	DOUBLE GUSSET	4	4.8.2	358-17-02-483	VERTICAL SPINDLE TUBE	2
1.6	358-03-00-355	GUSSET	4	4.8.3	358-83-01-230	SPINDLE SLEEVE	2
1.7	358-17-03-501	HANGER TUBE	2	4.8.4	395-01-01-004	REINFORCING PLATE	2
1.8	358-17-03-485	HANGER BRKT	2	4.8.5	394-01-03-056	FILLER BAR	4
1.9	358-17-03-489	FILLER PLATE	2	4.8.6	395-01-01-005	TUBE CAPS	2
1.10	358-17-03-500	"U" CHANNEL	2	4.8.7	358-17-02-498	SPINDLE SLEEVE GUSSET	4
1.11	358-17-03-509	BOTTOM CAP	2	4.8.8	358-17-02-502	REINFORCING CAP	2
2	358-11-00-000	16000LB DUCTILE HUB KIT	4	4.8.9	358-83-01-235	WALKER SLEEVE	1
3	358-17-06-000	LH TANDEM SIDE ASSY	1	4.8.10	358-01-00-401	"FRONT" PLATE	1
3.1	358-17-07-000	LH WALKING BEAM ASSY	1	4.9	358-17-06-517	REAR ARM GUSSET	2
3.1.1	358-17-07-510	WALKING BEAM	1	4.10	358-17-06-518	REAR ARM CAP	1
3.1.2	358-17-02-483	VERTICAL SPINDLE TUBE	2	4.11	358-17-06-519	FRONT ARM GUSSET	2
3.1.3	358-83-01-235	WALKER SLEEVE	1	4.12	358-17-06-520	FRONT ARM CAP	1
3.1.4	358-83-01-230	SPINDLE SLEEVE	2	4.13	358-17-06-521	CORNER GUSSET	2
3.1.5	395-01-01-004	REINFORCING PLATE	2	5	358-17-05-000	MAIN AXLE TUBE ASSY	1
3.1.6	394-01-03-056	FILLER BAR	4	5.1	340-63-00-538	STOP RING	1
3.1.7	395-01-01-005	TUBE CAPS	2	5.2	358-17-05-499	MAIN AXLE TUBE	1
3.1.8	358-17-02-498	SPINDLE SLEEVE GUSSET	4	6	340-00-00-347	16000 SPINDLE	4
3.1.9	358-17-02-502	REINFORCING CAP	2	7	340-00-00-346	RETAINING RING	1
3.1.10	358-01-00-401	"FRONT" PLATE	1	8	R20094	SPINDLE FLANGE NUT 1 3/4 - 12 UNF	4
3.2	358-83-01-235	WALKER SLEEVE	1	9	R07655	3/4-10 UNC x 2.5 HEX BOLT GR.5	8
3.3	358-17-06-511	CENTER CONNECTOR TUBE	1	10	R07827	3/4 FLAT WASHER STD - ZINC	16
3.4	358-17-06-512	FRONT TANDEM ARM	1	11	R07878	3/4-10 UNC NYLOCK NUT - ZINC	8
3.5	358-17-06-513	REAR TANDEM ARM	1	12	R07786	5/8-11 UNC HEX NUT - ZINC	9
3.6	358-17-06-514	REINFORCING PLATE	2	13	R07927	5/8-11 UNC x 1.5 SQ HD SET SCREW	8
3.7	358-17-06-515	TIE PLATE REAR	1	14	R20095	5/16 x 4 COTTER PIN - ZINC	4
3.8	358-17-06-516	TIE PLATE-FRONT	1	15	R07653	5/8-11 UNC x 6 HEX BOLT GR.5	1
3.9	358-17-06-517	REAR ARM GUSSET	2	16	R07806	5/8 LOCK WASHER - ZINC	1
3.10	358-17-06-518	REAR ARM CAP	1				

18000L 6" DISCHARGE PIPE KIT

18000L 6" DISCHARGE PIPE KIT
358-12-00-000

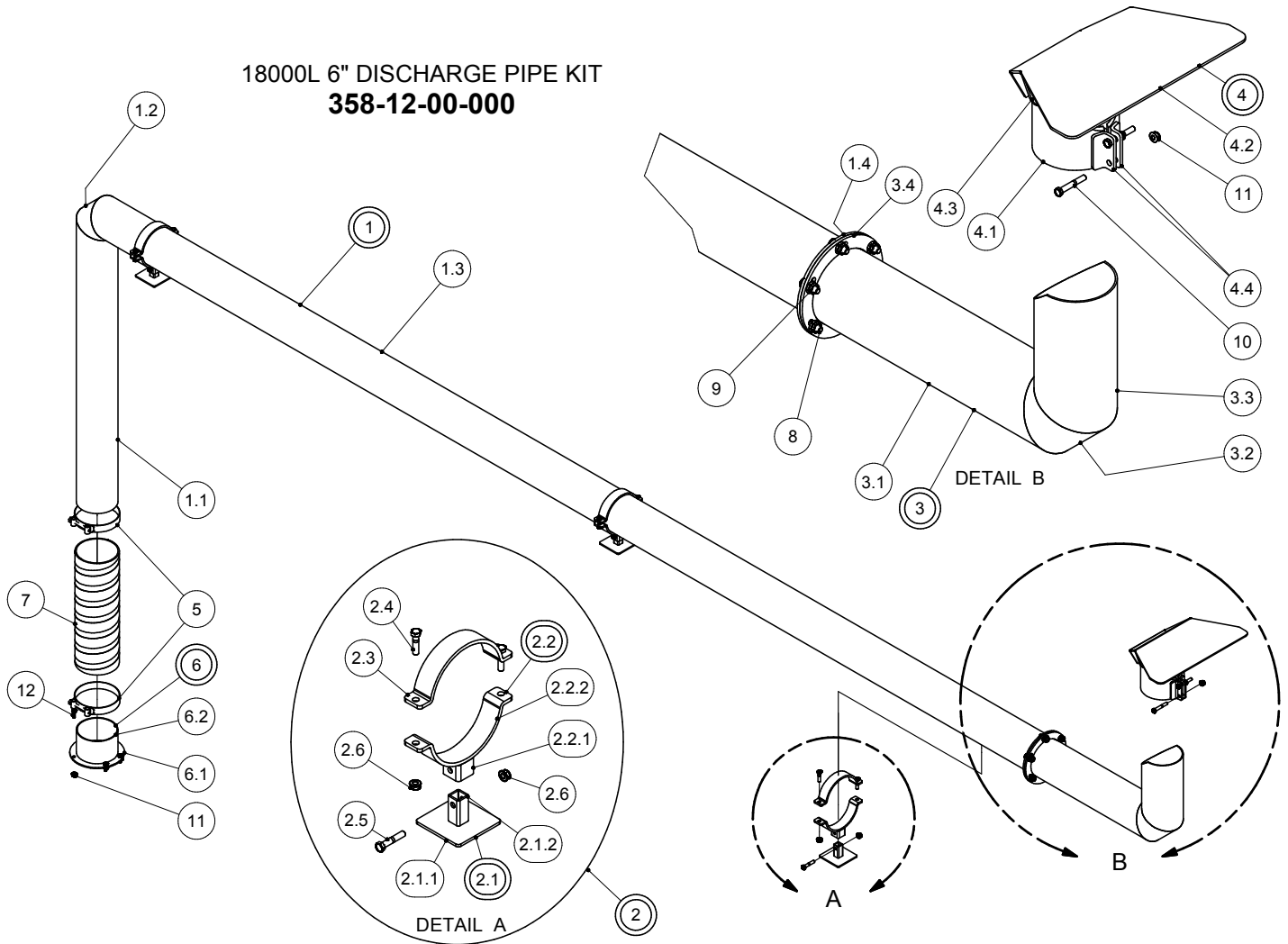

PARTS LIST				PARTS LIST			
ITEM	PART NUMBER	DESCRIPTION	QTY	ITEM	PART NUMBER	DESCRIPTION	QTY
1	358-32-00-000	6" DISCHARGE PIPE ASSY	1	3.2	364-19-00-082	DISCHARGE PIPE CORNER PC	1
1.1	358-32-00-109	VERTICAL DISCHARGE PIPE	1	3.3	364-25-00-067	DISCHARGE PIPE END PC	1
1.2	364-19-00-082	DISCHARGE PIPE CORNER PC	1	3.4	364-19-00-087	DISCHARGE PIPE FLANGE	1
1.3	359-30-00-108	DISCHARGE PIPE HORZ. PC	1	4	364-68-00-000	6" SPLASH PLATE ASSY	1
1.4	364-19-00-087	DISCHARGE PIPE FLANGE	1	4.1	364-68-00-215	CLAMPING TUBE	1
2	357-16-00-000	6" DISCHARGE PIPE HOLDER KIT	3	4.2	364-21-00-069	SPLASH PLATE	1
2.1	357-16-01-000	DISCHARGE PIPE BASE HOLDER ASSY	1	4.3	364-21-00-224	SPLASH PLATE WING	2
2.1.1	357-16-01-130	BASE PLATE	1	4.4	364-21-00-071	CLAMPING TUBE BRKT	2
2.1.2	357-16-01-131	LOWER STUB	1	5	R02482	6" HOSE CLAMP	2
2.2	357-16-02-000	PIPE HOLDER ASSY	1	6	364-31-00-000	HOSE TUBE ASSY - 6"	1
2.2.1	357-16-02-137	UPPER STUB	1	6.1	364-01-03-376	DISCHARGE RING	1
2.2.2	357-16-00-133	TOP PIPE HOLDER - 6"	1	6.2	364-01-03-063	DISCHARGE TUBE	1
2.3	357-16-00-133	TOP PIPE HOLDER - 6"	1	7	364-00-00-066	HOSE SECTION	1
2.4	R07620	3/8-16 UNC x 1.5 HEX BOLT GR.5	2	8	R07671	7/16-14 UNC x 1.25 HEX BOLT GR.5	6
2.5	R07621	3/8-16 UNC x 2 HEX BOLT GR.5	1	9	R07879	7/16-14 UNC FLANGE NUT - ZINC	6
2.6	R07794	3/8-16 UNC FLANGE NUT - ZINC	3	10	R07622	3/8-16 UNC x 2.5 HEX BOLT GR.5	2
3	364-25-00-000	DISCHARGE PIPE END SECTION ASSY	1	11	R07794	3/8-16 UNC FLANGE NUT - ZINC	7
3.1	364-25-00-088	DISCHARGE PIPE FLANGE PC	1	12	R07619	3/8-16 UNC x 1 HEX BOLT GR.5	5

18000L 8" DISCHARGE PIPE KIT

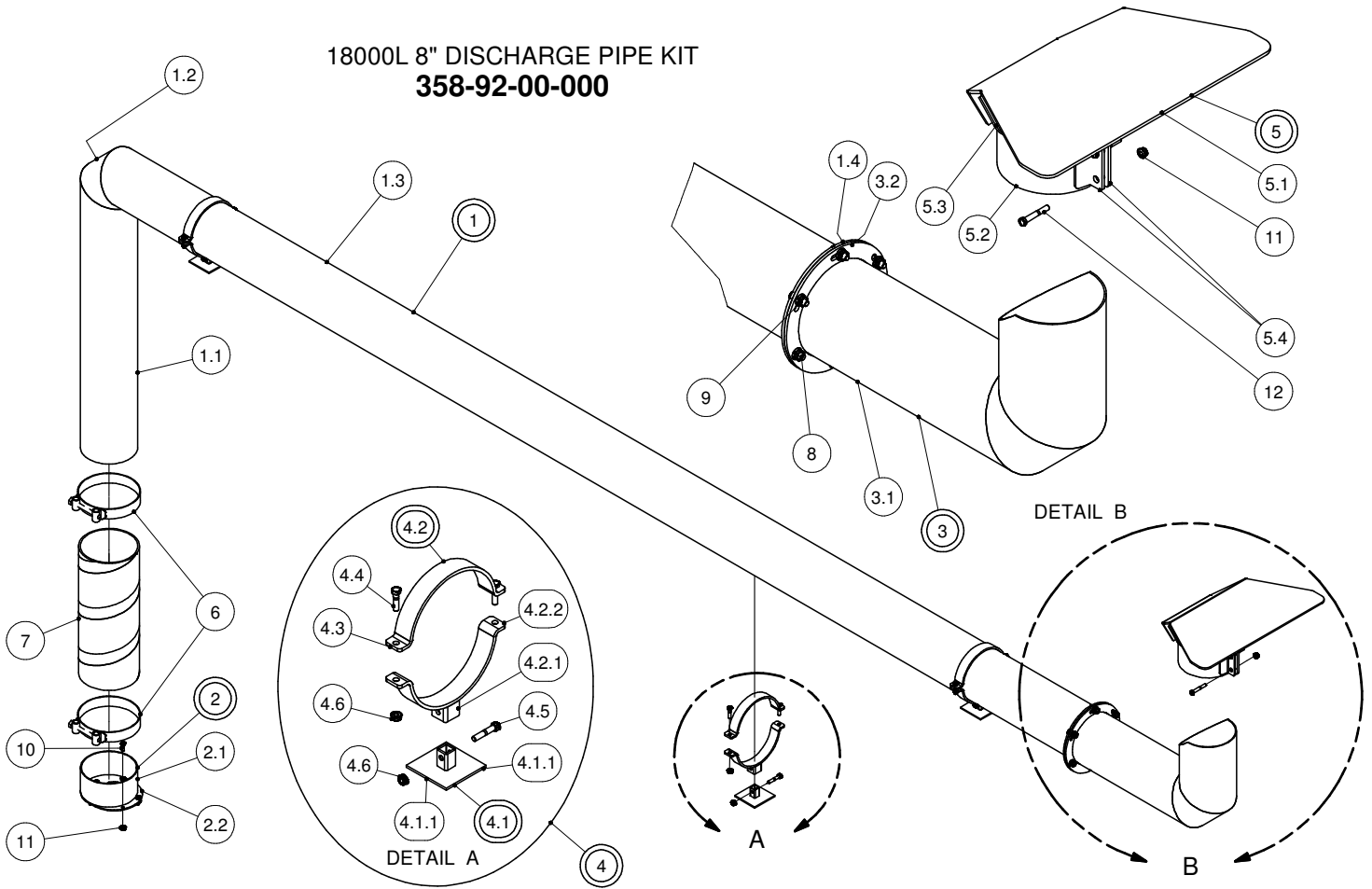

PARTS LIST				PARTS LIST			
ITEM	PART NUMBER	DESCRIPTION	QTY	ITEM	PART NUMBER	DESCRIPTION	QTY
1	358-92-02-000	8" DISCHARGE PIPE ASSY-18000L	1	4.2.2	357-17-00-135	TOP PIPE HOLDER - 8"	1
1.1	358-92-02-525	DISCHARGE VERTICAL PIPE	1	4.3	357-17-00-135	TOP PIPE HOLDER - 8"	1
1.2	358-92-02-524	DISCHARGE ELBOW PC	1	4.4	R07620	3/8-16 UNC x 1.5 HEX BOLT GR.5	2
1.3	358-92-02-303	8" HORIZONTAL DISCHARGE PIPE	1	4.5	R07621	3/8-16 UNC x 2 HEX BOLT GR.5	1
1.4	358-92-02-306	8" DISCHARGE FLANGE	1	4.6	R07794	3/8-16 UNC FLANGE NUT - ZINC	3
2	358-92-01-000	8" HOUSING RING & TUBE ASSY	1	5	358-92-04-000	8" SPLASH PLATE ASSY	1
2.1	358-92-01-302	8" HOUSING OUTLET TUBE	1	5.1	358-92-04-308	8" SPLASH PLATE	1
2.2	358-92-01-301	8" HOUSING DISCHARGE RING	1	5.2	358-92-04-309	8" SPLASH PLATE TUBE	1
3	358-92-03-000	8" EXTENSION PIPE ASSY	1	5.3	358-92-04-310	WING FOR 8" SPLASH PLATE	2
3.1	358-92-03-307	8" EXTENSION PIPE	1	5.4	358-92-04-311	CLAMPING TUBE BRKT	2
3.2	358-92-02-306	8" DISCHARGE FLANGE	1	6	R02484	8" SUCTION HOSE CLAMP	2
4	357-17-00-000	8" DISCHARGE PIPE HOLDER KIT	3	7	358-92-00-329	8" DISCHARGE HOSE	1
4.1	357-16-01-000	DISCH. PIPE BASE HOLDER ASSY	1	8	R07671	7/16-14 UNC x 1.25 HEX BOLT GR.5	6
4.1.1	357-16-01-130	BASE PLATE	1	9	R07879	7/16-14 UNC FLANGE NUT - ZINC	6
4.1.2	357-16-01-131	LOWER STUB	1	10	R07619	3/8-16 UNC x 1 HEX BOLT GR.5	5
4.2	357-17-01-000	PIPE HOLDER ASSY - 8"	1	11	R07794	3/8-16 UNC FLANGE NUT - ZINC	7
4.2.1	357-16-02-137	UPPER STUB	1	12	R07622	3/8-16 UNC x 2.5 HEX BOLT GR.5	2

FAN & HOUSING COMPLETE-TAPERED SHAFT

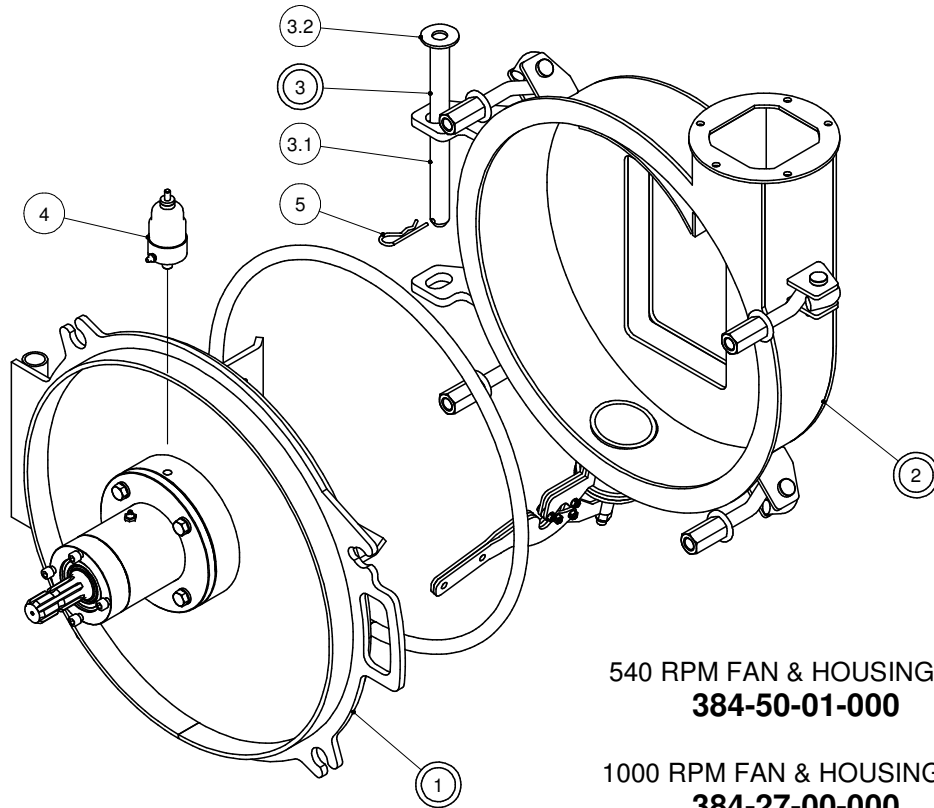

540 RPM FAN & HOUSING KIT
384-50-01-000

1000 RPM FAN & HOUSING KIT
384-27-00-000

PARTS LIST				PARTS LIST			
ITEM	PART NUMBER	DESCRIPTION	QTY	ITEM	PART NUMBER	DESCRIPTION	QTY
1	384-50-01-000	540 RPM FAN & COVER PLATE	1	3	376-02-04-000	LID PIN ASSY	1
		-TAPERED SHAFT		3.1	376-02-04-508	LID PIN	1
	384-27-00-000	1000 RPM FAN & COVER PLATE	1	3.2	R07827	3/4 FLAT WASHER STD - ZINC	1
		-TAPERED SHAFT		4	R10595	SPRING PRESSURE AUTO GREASE CUP	1
2	384-20-01-000	HOUSING ASSY-CHT(2007)	1	5	R07948	5/32 HAIR PIN	1
				6	R08368	3/8-16 UNC x 2.25 SHCS - BLK	2

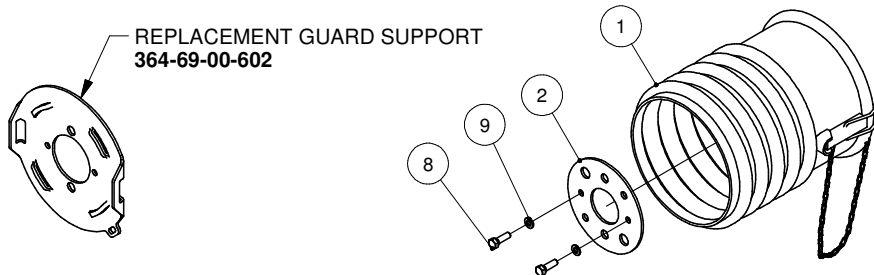

REPLACEMENT GUARD SUPPORT
364-69-00-602

PLASTIC PTO GUARD KIT
364-69-00-000

PARTS LIST				PARTS LIST			
ITEM	PART NUMBER	DESCRIPTION	QTY	ITEM	PART NUMBER	DESCRIPTION	QTY
1	R22196	SHEILD CONE ASSY	1	8	R07611	5/16-18 UNC x 1 HEX BOLT GR.5	2
2	364-00-00-448	PTO GUARD SUPPORT	1	9	R07802	5/16 LOCK WASHER - ZINC	2

COVER PLATE-TAPERED SHAFT

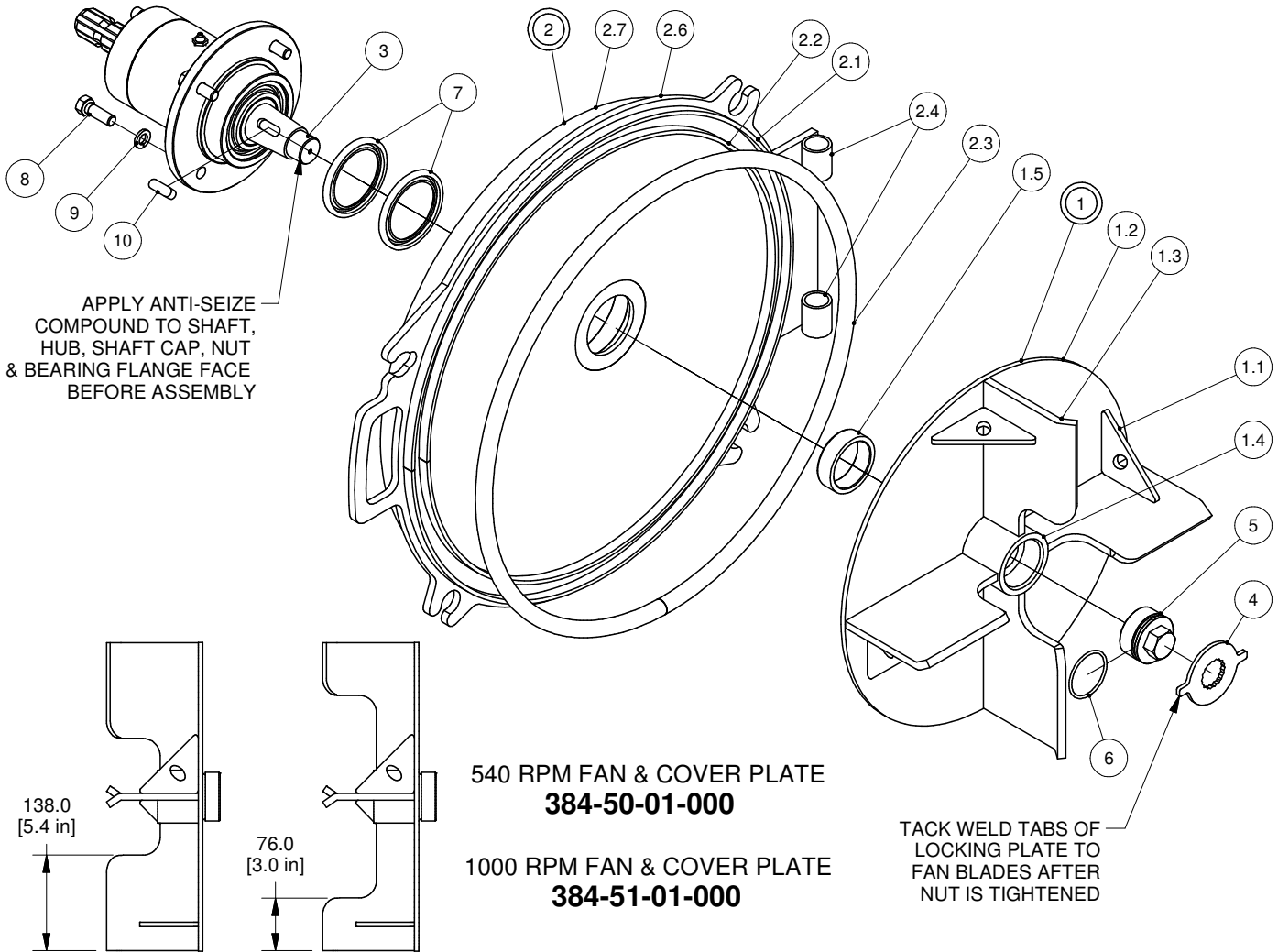

540 RPM FAN & COVER PLATE
384-50-01-000
 1000 RPM FAN & COVER PLATE
384-51-01-000

NOTES:

- ALWAYS GREASE SEALS AND SHAFT COLLAR BEFORE INSTALLATION
- ENSURE SEAL LIPS DO NOT "FOLD OVER" DURING ASSEMBLY

PARTS LIST				PARTS LIST			
ITEM	PART NUMBER	DESCRIPTION	QTY	ITEM	PART NUMBER	DESCRIPTION	QTY
1	384-50-02-000	TAPERED HUB FAN ASSY - 540 RPM CHT	1	2.5	384-50-03-642	MOTOR & BEARING BOX MOUNT	1
	384-51-02-000	TAPERED HUB FAN ASSY-1000 RPM CHT	1	2.6	384-50-03-641	COVER PLATE-TAPERED SHAFT	1
1.1	364-72-00-422	FAN BLADE GUSSET	4	2.7	384-27-02-534	REIN. RING-1000 RPM COVER PLATE	1
1.2	384-33-03-417	FAN BACK PLATE	1	3	384-50-04-000	BEARING KIT 1-3/8"-6T - TAPERED SHAFT	1
1.3	384-33-03-419	CHT 540 RPM FAN BLADE	4	4	384-50-01-647	TAPERED HUB LOCKING PLATE	1
1.4	384-50-02-639	TAPERED IMPELLER HUB	1	5	384-50-01-648	TAPERED SHAFT CAP NUT	1
1.5	R23443	HARDENED SEAL COLLAR - 2.75" OD	1	6	R23444	O-RING #226 - 2.25" OD x 2" ID	1
2	384-50-03-000	COVER PLATE ASSY - TAPERED SHAFT	1	7	R23441	GREASE SEAL HM21 - 2.750" x 3.751" x .25"	2
2.1	384-20-03-295	OUTER RING	1	8	R07638	1/2-13 UNC x 1.5 HEX BOLT GR.5	4
2.2	384-20-03-296	INNER RING	1	9	R07805	1/2 LOCK WASHER - ZINC	4
2.3	384-20-00-301	RUBBER SEAL	1	10	R23507	MACHINE KEY - 7/16" SQ x 1-1/4"	1
2.4	384-20-03-570	HATCH PIN SLEEVE	2				

BEARING KIT-TAPERED SHAFT

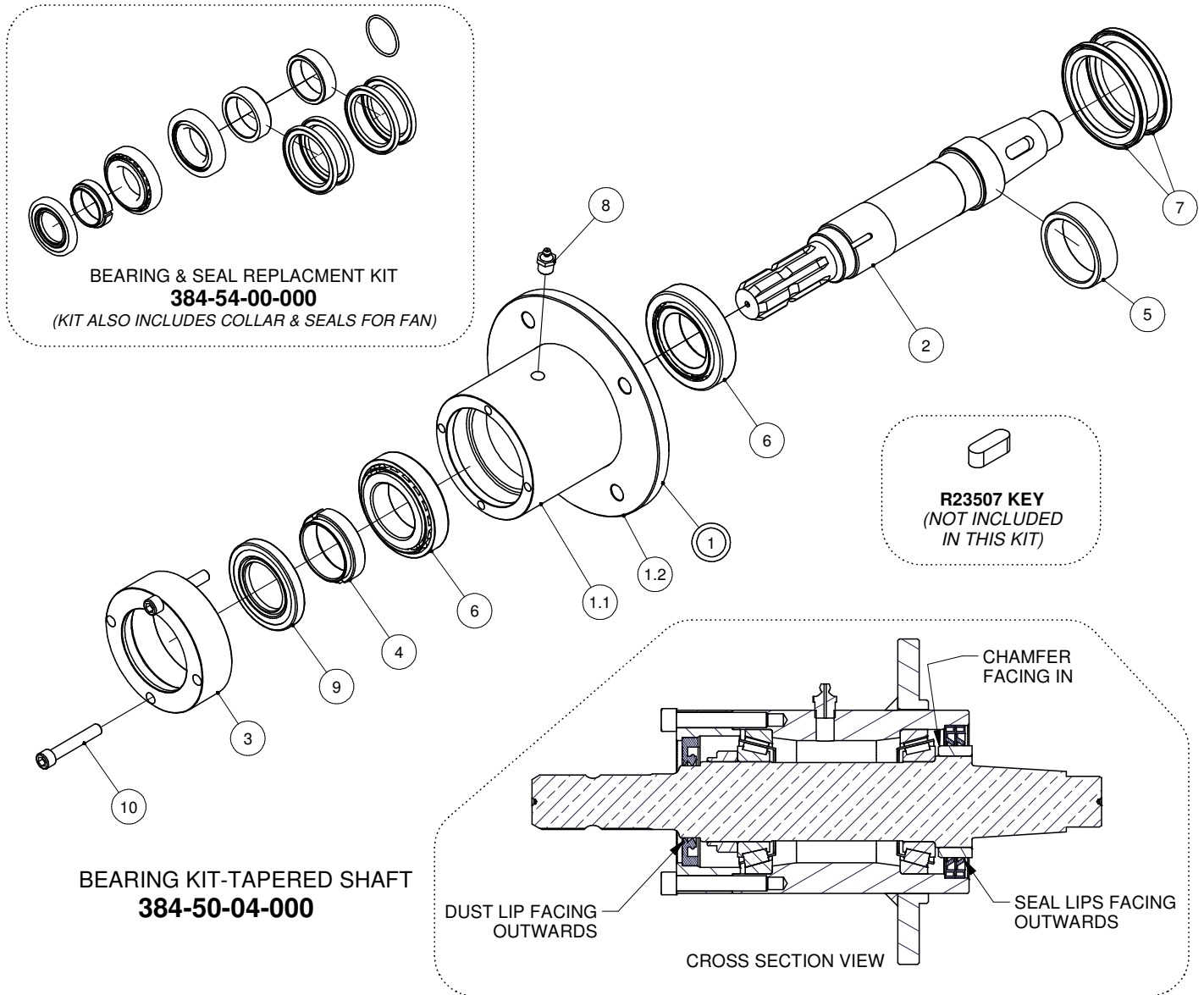

PARTS LIST			
ITEM	PART NUMBER	DESCRIPTION	QTY
1	384-50-05-000	BEARING TUBE ASSY-TAPERED SHAFT	1
1.1	384-50-05-643	TAPERED SHAFT BEARING TUBE	1
1.2	384-50-05-644	BEARING TUBE FLANGE	1
2	384-50-04-637	TAPERED FAN SHAFT - 1-3/8"-6T	1
3	384-50-04-645	TAPERED SHAFT BEARING TUBE CAP	1
4	384-50-04-646	STAKE NUT - M50-1.5	1
5	R23443	HARDENED SEAL COLLAR - 2.75" OD	1
6	R23429	TAPERED ROLLER BEARING - 50 x 90 x 21.75	2
7	R23441	GREASE SEAL HM21 - 2.750" x 3.751" x .25"	2
8	R08188	1/4" NPT STRAIGHT GREASE FTG	1
9	R23442	SEAL D.L. - 45 x 80 x 10 HMSA10 RG	1
10	R08368	3/8-16 UNC x 2.25 SHCS - BLK	2

SWING AWAY HOUSING ASSY-CHT

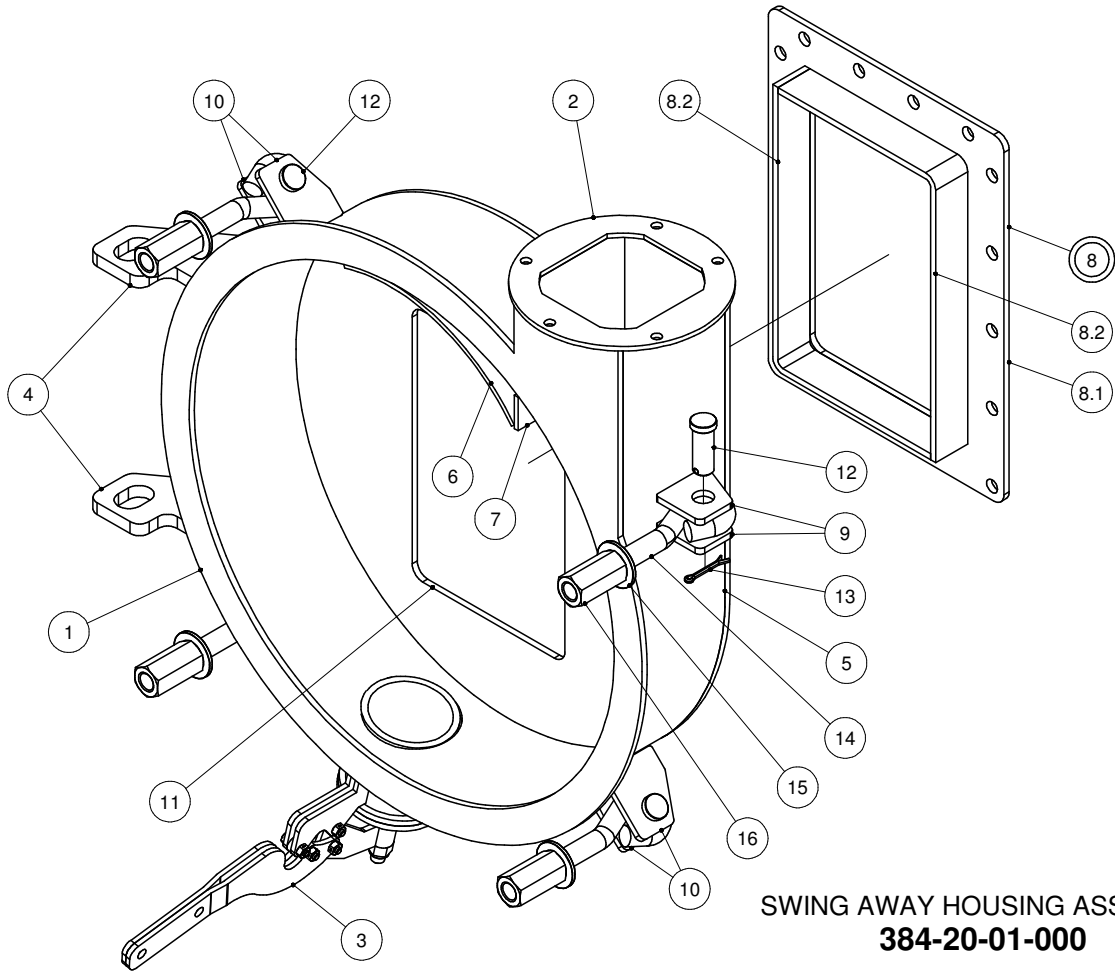

**SWING AWAY HOUSING ASSY-CHT
384-20-01-000**

PARTS LIST			
ITEM	PART NUMBER	DESCRIPTION	QTY
1	384-20-01-289	HOUSING FLANGE	1
2	364-01-03-376	DISCHARGE RING	1
3	364-62-00-000	DRAIN PLUG KIT	1
4	384-20-01-290	DOOR HINGE	2
5	357-48-01-232	CHT HOUSING BAND	1
6	357-48-01-231	CHT HOUSING BAND AID	1
7	357-48-01-230	CHT FAN HOUSING VERTICAL PC	1
8	357-48-02-000	CHT HOUSING INLET FLANGE ASSY	1
8.1	364-81-02-393	HOUSING FLANGE	1
8.2	357-48-02-233	CHT INLET EXTENSION	2
9	384-20-01-424	SHORT HOUSING LUG	2
10	384-20-01-423	HOUSING LUG	6
11	357-48-01-228	CHT HOUSING BACK PLATE	1
12	R08443	EYE BOLT PIN	4
13	R08207	5/32 x 1 1/2 COTTER PIN - SS	4
14	R08442	3/4" EYE BOLT	4
15	376-02-00-577	MANWAY WASHER	4
16	R07800	3/4-10 UNC COUPLING NUT - ZINC	4

HYD FAN & HOUSING COMPLETE -TAPERED SHAFT 26 GPM

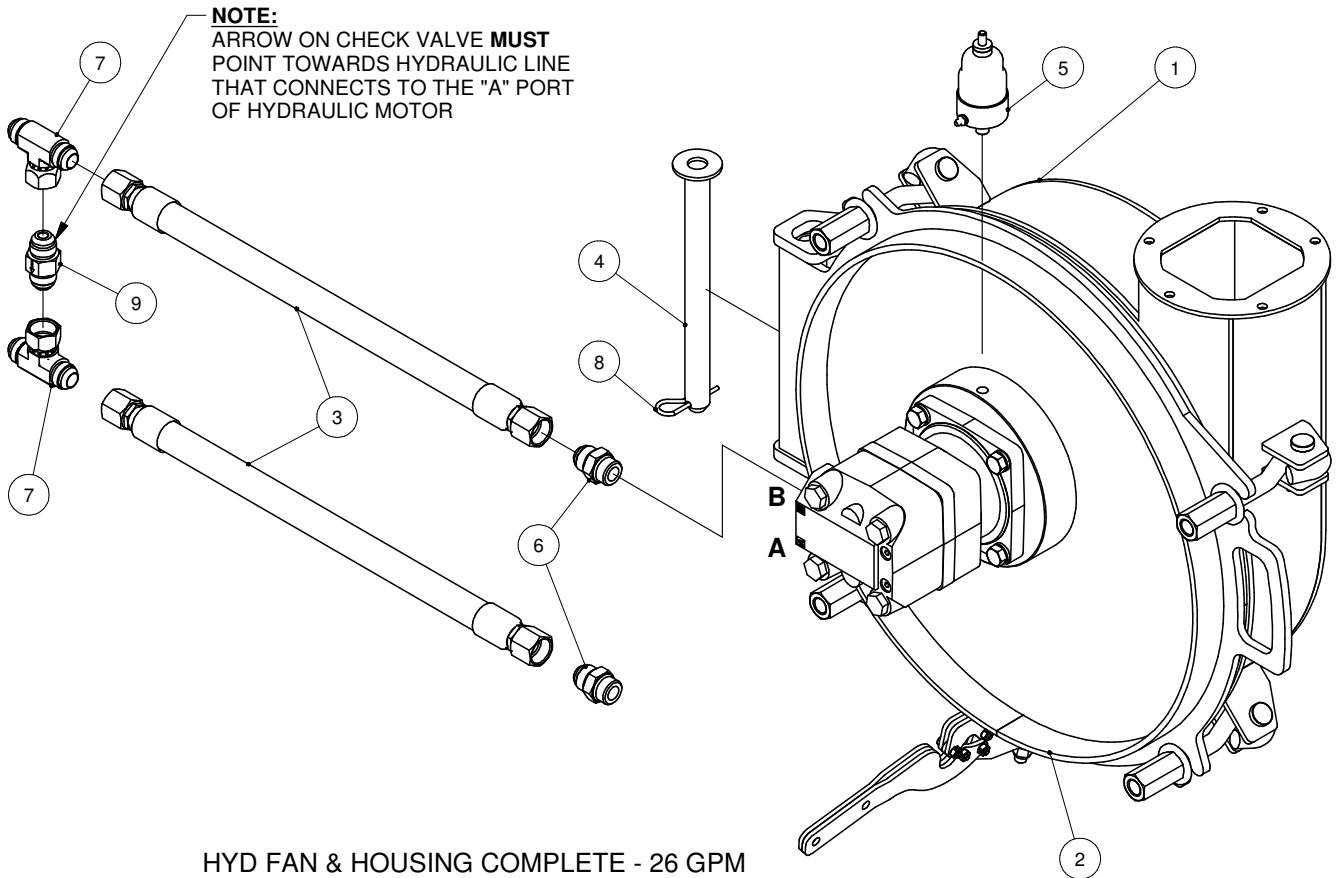

R23512
REPLACEMENT SEAL KIT FOR MLHT160T4A
HYD MOTOR w/ TAPERED SHAFT

PARTS LIST			
ITEM	PART NUMBER	DESCRIPTION	QTY
1	384-20-01-000	HOUSING ASSY-CHT(2007)	1
2	384-52-01-000	HYD FAN & COVER PLATE-TAPERED SHAFT-26 GPM	1
3	384-35-03-000	3/4" HYDRAULIC HOSE ASSY	2
4	376-02-04-000	LID PIN ASSY	1
5	R10595	SPRING PRESSURE AUTO GREASE CUP	1
6	R23098	ORB-12 x 3/4" JIC M. ADAPTOR	2
7	R23122	3/4" M. x 3/4" M. x 3/4" SW F. JIC TEE	2
8	R07948	5/32 HAIR PIN	1
9	R23447	3/4" M. JIC CHECK VALVE	1

HYD FAN & COVER PLATE-TAPERED SHAFT

M&S MLHT160 26.4 MAX GPM } 2900 MAX PSI
 M&S MLHT200 33 MAX GPM }

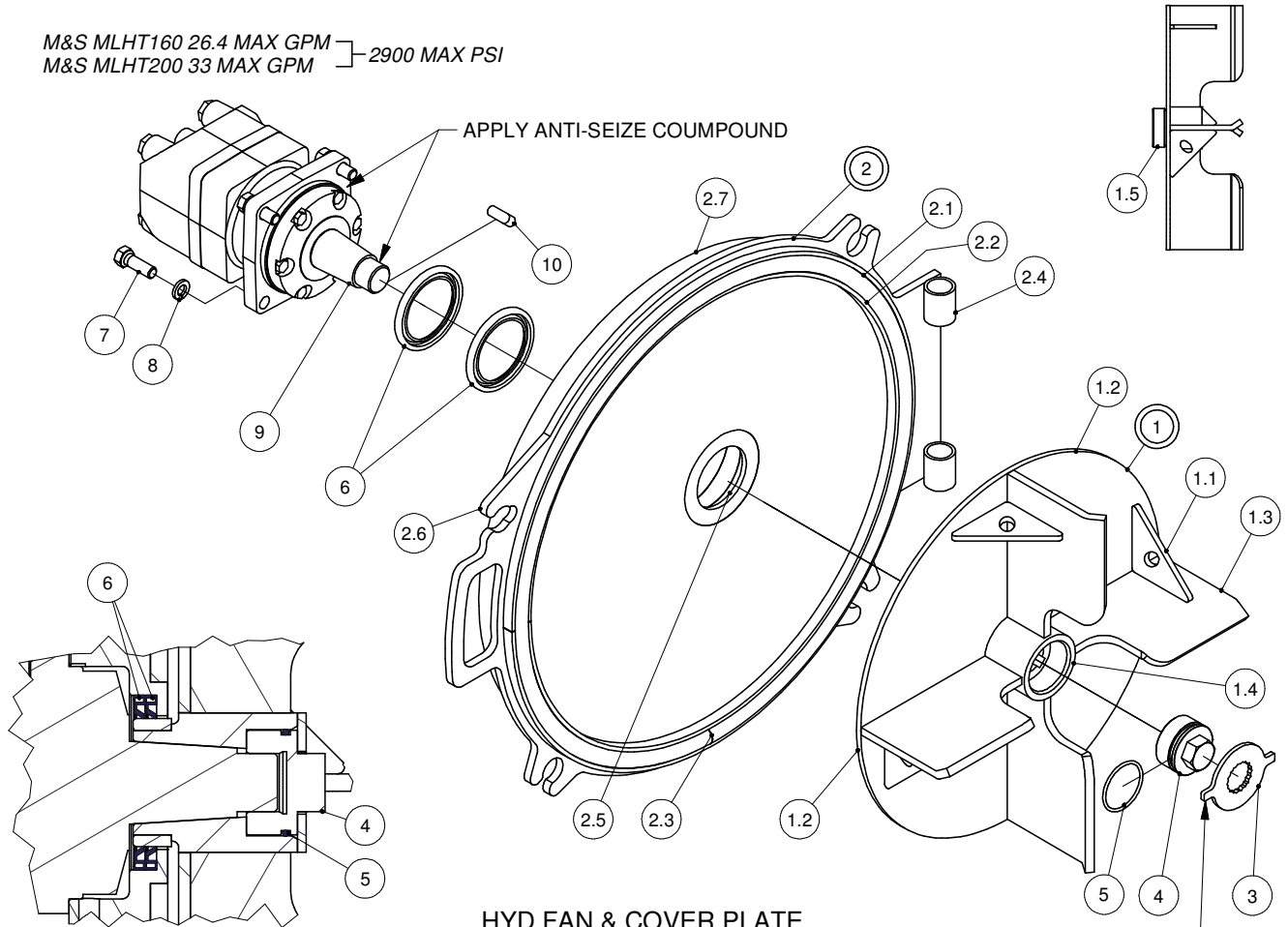

SEAL DETAIL
 SEAL LIP MUST FACE
 AWAY FROM HYD MOTOR

HYD FAN & COVER PLATE
384-52-01-000 - 26 GPM

HYD FAN & COVER PLATE
384-55-01-000 - 33 GPM

TACK WELD TABS
 OF LOCKING PLATE
 TO FAN BLADES AFTER
 NUT HAS BEEN TIGHTENED

R23512
 REPLACEMENT SEAL KIT FOR MLHT160/200T4A
 HYD MOTOR W/ TAPERED SHAFT

NOTES:

- ALWAYS GREASE SEALS AND SHAFT COLLAR BEFORE INSTALLATION
- ENSURE SEAL LIPS DO NOT "FOLD OVER" DURING ASSEMBLY

PARTS LIST				PARTS LIST			
ITEM	PART NUMBER	DESCRIPTION	QTY	ITEM	PART NUMBER	DESCRIPTION	QTY
1	384-50-02-000	TAPERED HUB FAN ASSY - 540 RPM CHT	1	2.7	384-27-02-534	REIN. RING-1000 RPM COVER PLATE	1
1.1	364-72-00-422	FAN BLADE GUSSET	4	3	384-50-01-647	TAPERED HUB LOCKING PLATE	1
1.2	384-33-03-417	FAN BACK PLATE	1	4	384-50-01-648	TAPERED SHAFT CAP NUT	1
1.3	384-33-03-419	CHT 540 RPM FAN BLADE	4	5	R23444	O-RING #226 - 2.25" OD x 2" ID	1
1.4	384-50-02-639	TAPERED IMPELLER HUB	1	6	R23441	GREASE SEAL HM21 - 2.750" x 3.751" x .25"	2
1.5	R23443	HARDENED SEAL COLLAR - 2.75" OD	1	7	R07638	1/2-13 UNC x 1.5 HEX BOLT GR.5	4
2	384-50-03-000	COVER PLATE ASSY - TAPERED SHAFT	1	8	R07805	1/2 LOCK WASHER - ZINC	4
2.1	384-20-03-295	OUTER RING	1	9	R23506	M+S HYD MOTOR-MLHT160 TAPERED SHAFT-26 GPM	1
2.2	384-20-03-296	INNER RING	1		R22590	M+S HYD MOTOR-MLHT200 TAPERED SHAFT-33 GPM	1
2.3	384-20-00-301	RUBBER SEAL	1				
2.4	384-20-03-570	HATCH PIN SLEEVE	2				
2.5	384-50-03-642	MOTOR & BEARING BOX MOUNT	1	10	R23507	MACHINE KEY - 7/16" SQ x 1-1/4"	1
2.6	384-50-03-641	COVER PLATE-TAPERED SHAFT	1				

DRAIN PLUG KIT

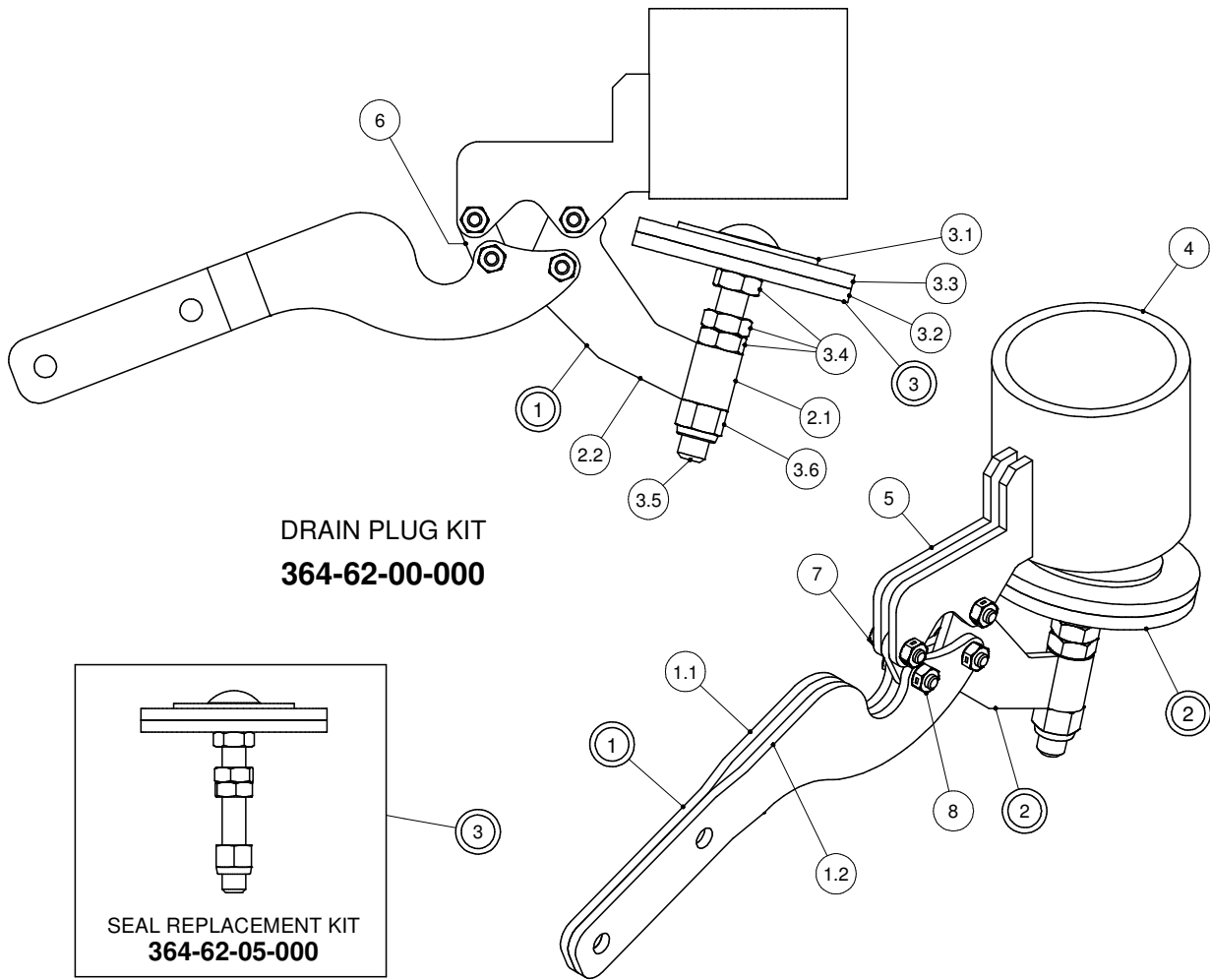

PARTS LIST

ITEM	PART NUMBER	DESCRIPTION	QTY
1	364-62-03-000	HANDLE ASSY	1
1.1	364-62-03-206	LH HANDLE	1
1.2	364-62-03-207	RH HANDLE	1
2	364-62-01-000	DRAIN PLUG SLEEVE ASSY	1
2.1	364-62-01-201	SLEEVE	1
2.2	364-62-01-200	SLEEVE LINKAGE	1
3	364-62-05-000	DRAIN PLUG REPLACEMENT KIT	1
3.1	364-62-04-370	PLUG WASHER	1
3.2	364-62-02-203	PLUG PLATE	1
3.3	R03071	DRAIN PLUG GASKET	1
3.4	R08046	1/2-13 UNC HEX JAM NUT - ZINC	3
3.5	R07748	1/2-13 UNC x 4 FULL THREAD CARRIAGE BOLT Gr.5	1
3.6	R08219	1/2-13 UNC NYLOCK NUT - ZINC	1
4	364-01-03-110	DRAIN PIPE	1
5	364-62-00-199	PLUG HOUSING BRKT	2
6	364-62-00-205	SHORT LINKAGE	1
7	R07176	1/4-20 UNC x 0.875 SHOULDER HEX BOLT GR.5	4
8	R08048	1/4-20 UNC 2-WAY LOCK NUT - ZINC	4

TAIL LIGHT KIT

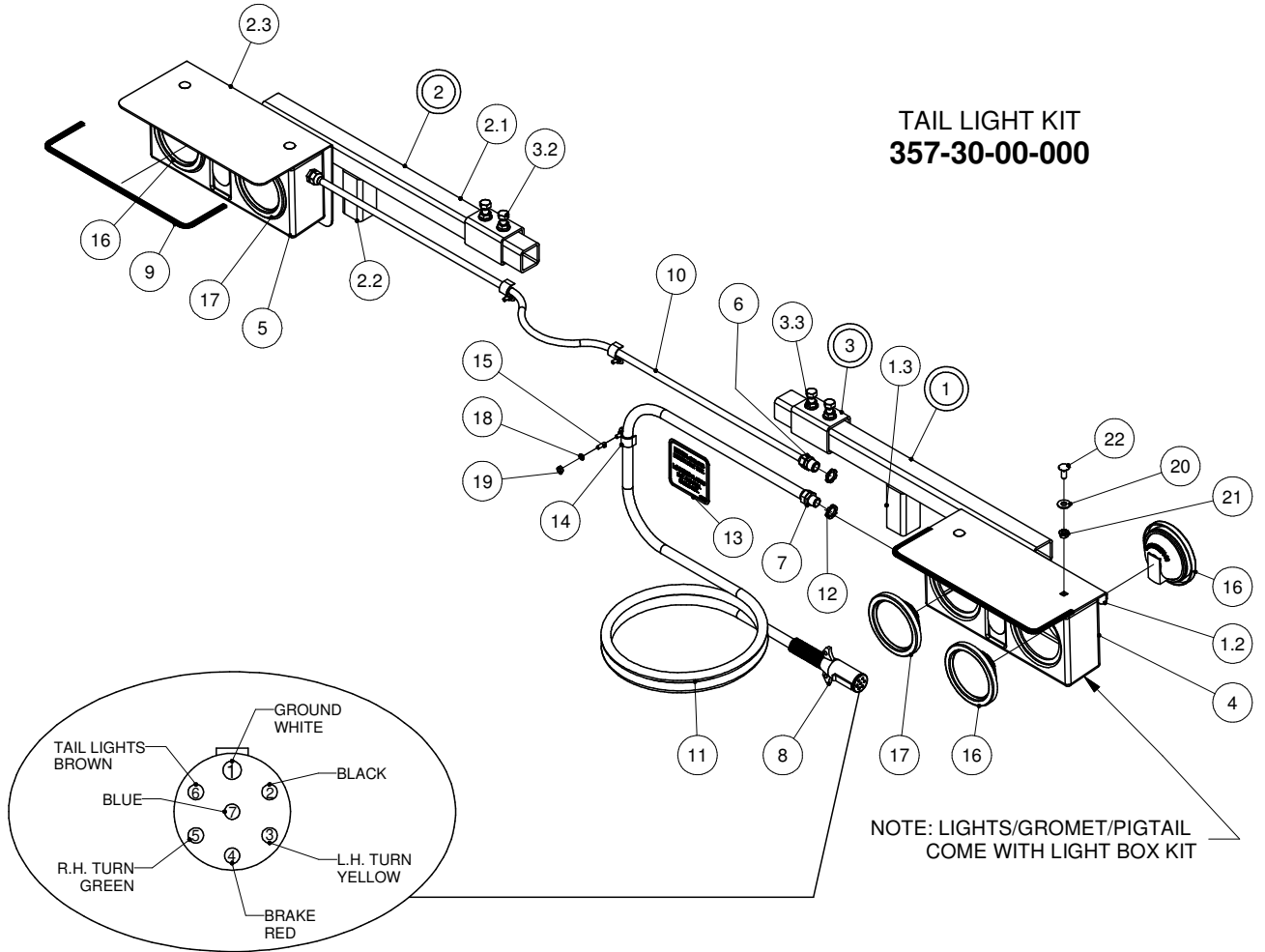

WIRING DIAGRAM
FOR 7 POLE CONNECTOR

PARTS LIST				PARTS LIST			
ITEM	PART NUMBER	DESCRIPTION	QTY	ITEM	PART NUMBER	DESCRIPTION	QTY
1	357-30-01-000	RH LIGHT BAR ASSY	1	8	R10095	7 POLE CONNECTOR w/ STRAIN RELIEF	1
1.1	357-30-01-171	LIGHT BAR	1				
1.2	357-30-01-172	RH LITE BOLT PLATE	1	9	357-30-00-311	SAFETY EDGING	2
1.3	357-30-01-173	STUB BAR	1	10	R04046	4-WIRE TRAILER CABLE - APPROX. 4M	1
2	357-30-02-000	LH LIGHT BAR ASSY	1	11	R04235	14/6 TRAILER CABLE - APPROX. 10.5M	1
2.1	357-30-01-171	LIGHT BAR	1	12	R10345	1/2" ELECTRICAL BOX LOCK NUT	3
2.2	357-30-01-173	STUB BAR	1	13	R09808	CABLE - LIGHT BOX DECAL	1
2.3	357-30-02-245	LH LITE BOLT PLATE	1	14	R21104	HYD. HOSE CLIPS	11
3	357-30-03-000	MOUNT BRKT ASSY	2	15	R08329	1/4-20 UNC x 3/4" WELD STUD	12
3.1	357-30-03-174	MOUNT BRKT	1	16	R10588	4" YELLOW LED LIGHT KIT	4
3.2	R07674	1/2-13 UNC x 1.25 HEX BOLT GR.5	2	17	R10358	4" RED LED LIGHT KIT	2
3.3	R07795	1/2-13 UNC FLANGE NUT - ZINC	2	18	R07801	1/4 LOCK WASHER - ZINC	11
4	R10349	RH LAMP BOX W/NO LIGHTS	1	19	R07781	1/4-20 UNC HEX NUT - ZINC	11
5	R10348	LH LAMP BOX W/ NO LIGHTS	1	20	R07823	3/8 FLAT WASHER STD - ZINC	4
6	R10193	1/2" NYLON TITE CONNECTOR	2	21	R07794	3/8-16 UNC FLANGE NUT - ZINC	4
7	R10357	3/4" NYLON TITE CONNECTOR	1	22	R07721	3/8-16 UNC x 1 CARRIAGE BOLT Gr.5	4

SIGHT GAUGE KIT

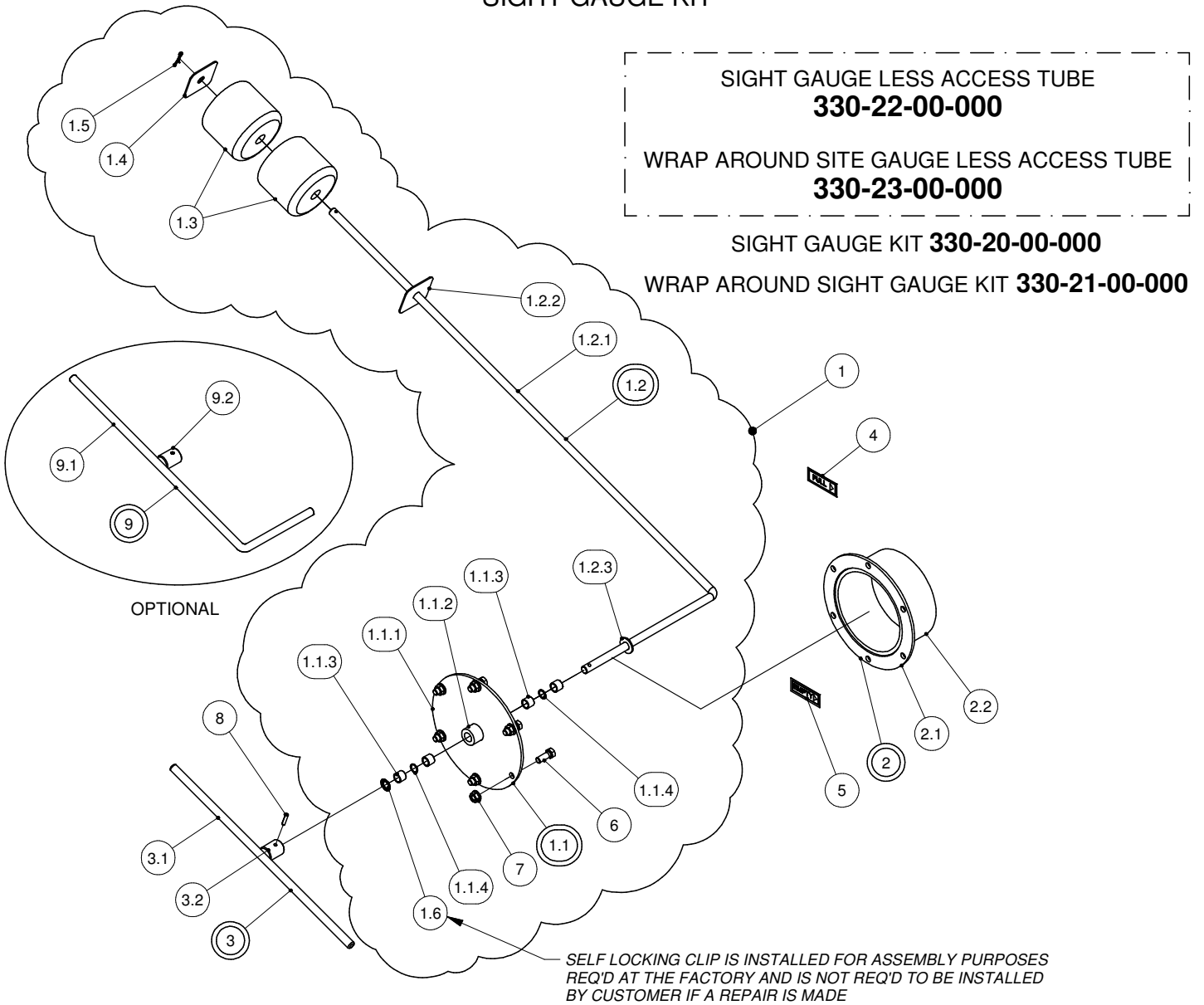

PARTS LIST				PARTS LIST			
ITEM	PART NUMBER	DESCRIPTION	QTY	ITEM	PART NUMBER	DESCRIPTION	QTY
1	330-22-01-000	SIGHT GAUGE w/o INDICATOR	1	2	330-20-03-000	ACCESS TUBE ASSY	1
1.1	330-20-04-000	COVER PLATE ASSY	1	2.1	330-20-03-560	ACCESS TUBE FLANGE	1
1.1.1	330-20-00-557	COVER PLATE	1	2.2	330-20-03-556	ACCESS TUBE	1
1.1.2	330-20-04-562	BUSHING HOLDER	1	3	330-20-02-000	INDICATOR ARM ASSY	1
1.1.3	R21173	1/2 x 5/8 x 1/2" BRONZE BUSHING	4	3.1	330-20-02-554	INDICATOR ARM	1
1.1.4	R20865	O-RING #11-014	2	3.2	330-20-02-553	INDICATOR ARM HUB	1
1.2	330-20-01-000	FLOAT ARM ASSY	1	4	R09529	"FULL" DECAL	1
1.2.1	330-20-01-551	FLOAT ARM	1	5	R09530	"EMPTY" DECAL	1
1.2.2	330-20-01-552	FLOAT STRAPS	1	6	R07619	3/8-16 UNC x 1 HEX BOLT GR.5	6
1.2.3	R08222	1/2 FLAT WASHER SAE - SS	1	7	R07794	3/8-16 UNC FLANGE NUT - ZINC	6
1.3	R09524	FLOAT	2	8	R08241	3/16 x 1 ROLL PIN - SS	1
1.4	330-20-01-552	FLOAT STRAPS	1	9	330-21-01-000	WRAP AROUND SITE ARM ASSY	1
1.5	R08021	1/8 x 1 S.S. COTTER PIN	1	9.1	330-19-46-546	WRAP AROUND SITE ARM	1
1.6	R08514	1/2" EXT. RETAINING RING	1	9.2	330-20-02-553	INDICATOR ARM HUB	1

BUTTERFLY LID & SAFETY GRATE

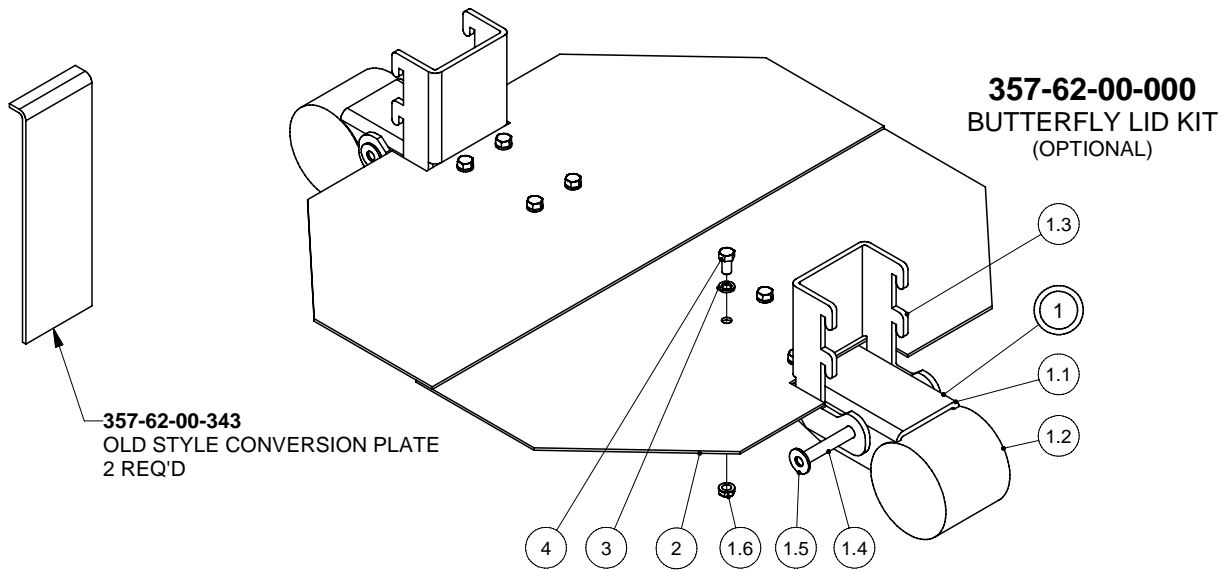

NOTE: WITH INSTALLATION OF A BUTTERFLY LID, A SAFETY GRATE MUST BE USED TO LOCK LID IN PLACE

PARTS LIST				PARTS LIST			
ITEM	PART NUMBER	DESCRIPTION	QTY	ITEM	PART NUMBER	DESCRIPTION	QTY
1	357-62-01-000	BUTTERFLY HINGE KIT	2	1.5	R07824	7/16 FLAT WASHER	2
1.1	357-62-01-316	U - CHANNEL HINGE	1	1.6	R07794	3/8 FLANGE NUT	4
1.2	357-62-01-317	COUNTER WEIGHT	1	2	357-62-00-318	BUTTERFLY LID	2
1.3	357-62-01-319	DROP-IN HINGE	1	3	R08319	3/8 S.S. LOCK WASHER	8
1.4	357-62-01-315	HINGE PIN	1	4	R08317	3/8 x 3/4 S.S. HEX BOLT	8

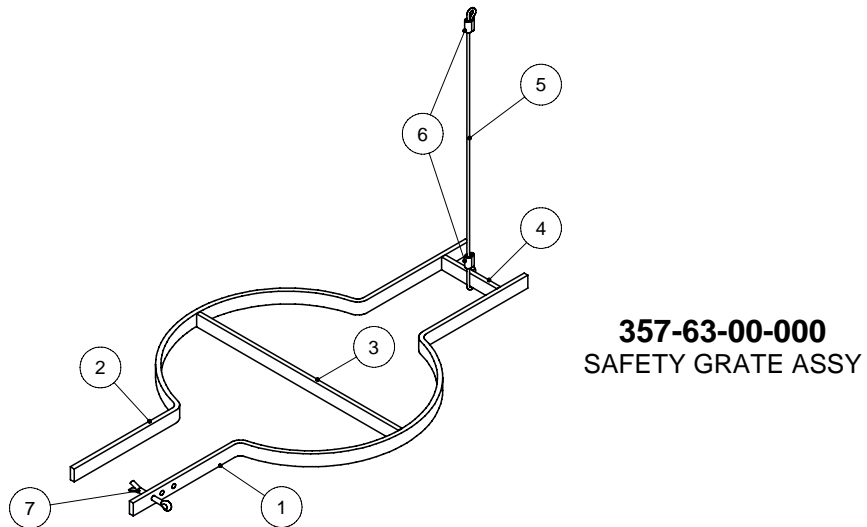

PARTS LIST			
ITEM	PART NUMBER	DESCRIPTION	QTY
1	357-63-00-320	SAFETY BAR w/ HOLE	1
2	357-63-00-332	SAFETY BAR	1
3	357-63-00-321	CROSS SAFETY BAR	1
4	357-63-00-322	STOP BAR	1
5	357-63-00-331	SAFETY CABLE	1
6	R08068	1/8" ALUMINUM CRIMP SLEEVES	2
7	R08016	1/4 x 2 COTTER PIN	1

LADDER KIT

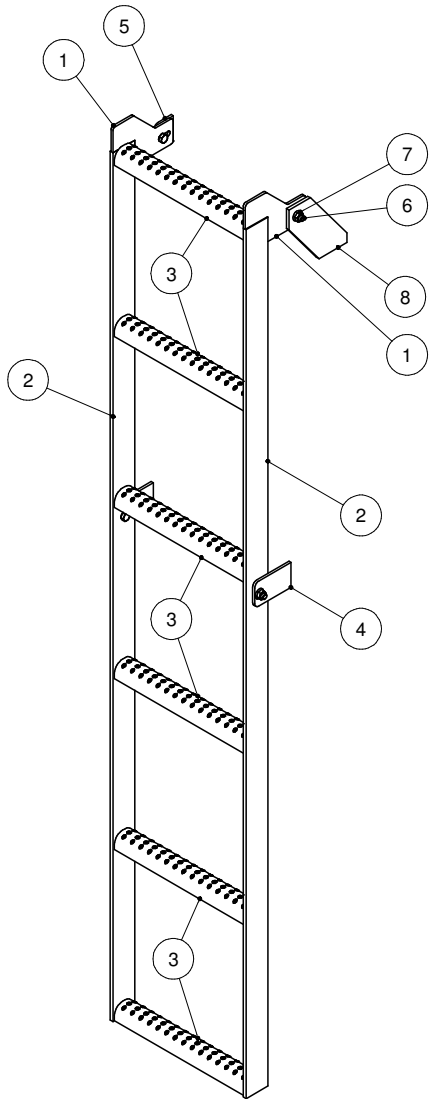

LADDER KIT
364-95-00-000

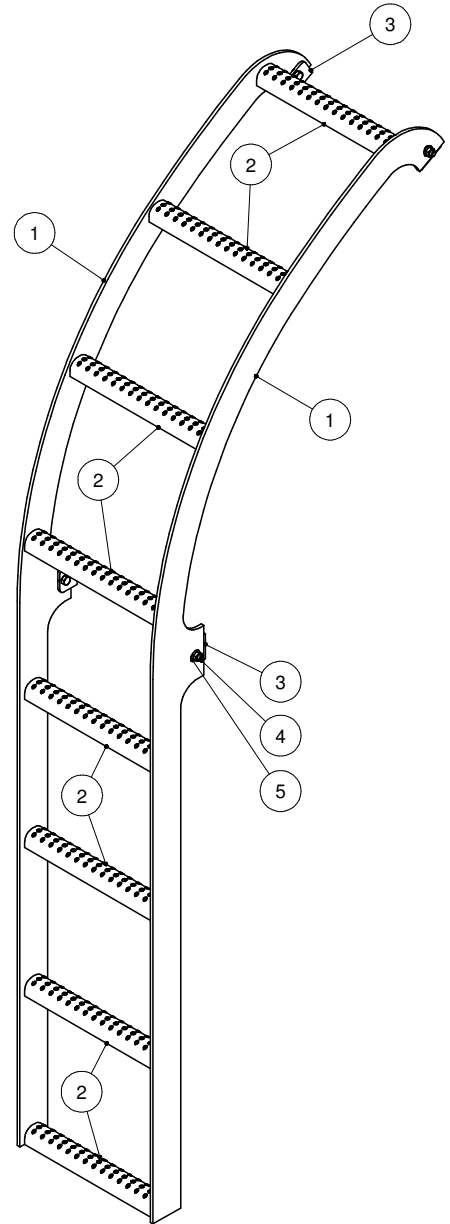

SIDE LADDER KIT
15000L PROFILE
385-39-00-000

PARTS LIST			
ITEM	PART NUMBER	DESCRIPTION	QTY
1	364-95-00-326	LADDER LUG	2
2	364-95-00-325	LADDER SIDE PC	2
3	364-95-00-324	LADDER RUNG	6
4	364-00-00-414	TANK LUG	2
5	364-95-00-327	UPPER TANK LUG	2
6	R07619	3/8-16 UNC x 1 HEX BOLT GR.5	4
7	R07794	3/8-16 UNC FLANGE NUT - ZINC	4
8	384-00-00-216	LADDER BRKT	1

PARTS LIST			
ITEM	PART NUMBER	DESCRIPTION	QTY
1	385-39-00-582	15000 PROFILE SIDE LADDER PC	2
2	364-95-00-324	LADDER RUNG	8
3	364-95-00-327	UPPER TANK LUG	4
4	R07619	3/8-16 UNC x 1 HEX BOLT GR.5	4
5	R07794	3/8-16 UNC FLANGE NUT - ZINC	4

TANK VENT KIT

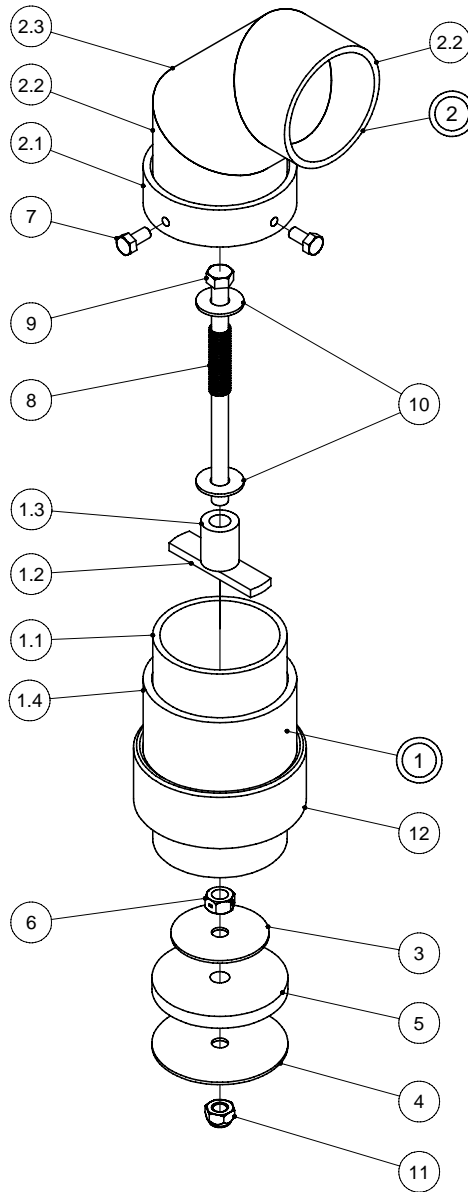

TANK VENT KIT
357-51-00-000
(OPTIONAL)

PARTS LIST				PARTS LIST			
ITEM	PART NUMBER	DESCRIPTION	QTY	ITEM	PART NUMBER	DESCRIPTION	QTY
1	357-51-01-000	VENT TUBE ASSY	1	4	357-51-00-258	LOWER STAINLESS STEEL WASHER	1
1.1	357-51-01-246	VENT TUBE	1	5	357-51-00-334	RUBBER PLUG	1
1.2	357-51-01-247	VENT STRAP	1	6	R07891	7/16 2-WAY LOCK NUT	1
1.3	357-51-01-248	INNER SLIDE TUBE	1	7	R07690	5/16 x 5/8 HEX BOLT	2
1.4	357-51-01-335	OUTER NIPPLE	1	8	357-51-00-249	SPRING	1
2	357-51-02-000	CAP ASSY	1	9	R07689	7/16 x 7 HEX BOLT	1
2.1	357-51-02-251	SLEEVE	1	10	R07833	7/16" SAE FLAT WASHER	2
2.2	357-51-02-252	ELBOW SECTION	2	11	R08178	7/16 NYLOCK HEX NUT	1
2.3	357-51-02-253	ELBOW MIDDLE SECTION	1	12	R02969	3 1/2" HALF COUPLER	1
3	357-51-00-250	STAINLESS STEEL WASHER	1				

KNOTT 2x60 BRAKE KIT-16K HUBS

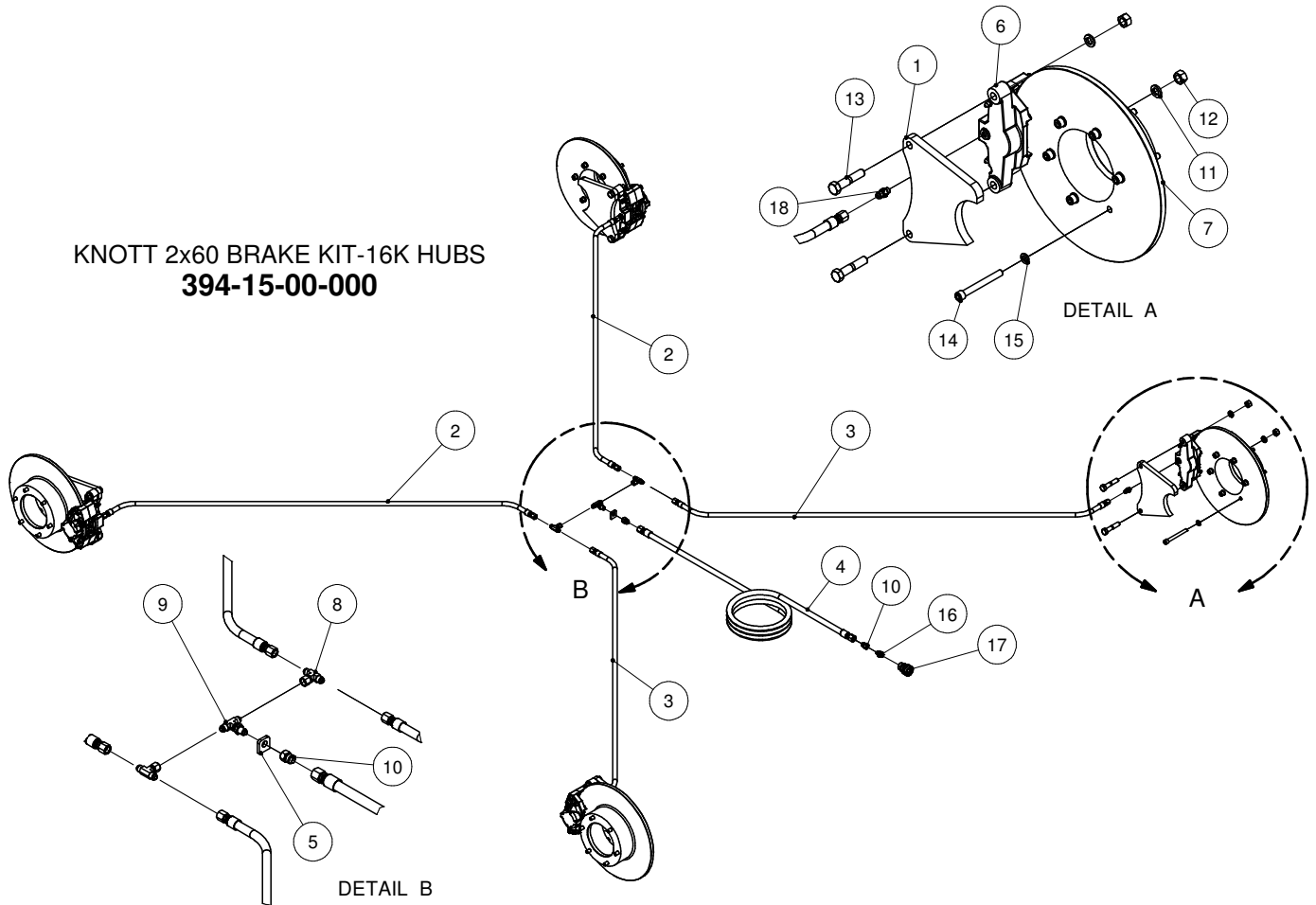

KNOTT 2x60 BRAKE KIT-16K HUBS
394-15-00-000

PARTS LIST

ITEM	PART NUMBER	DESCRIPTION	QTY
1	394-15-00-106	KNOTT 2x60 CALIPER MOUNT PLATE-16K	4
2	394-15-01-000	BRAKE HOSE ASSY 3/8" - REAR	2
3	394-15-02-000	BRAKE HOSE ASSY 3/8" - FRONT	2
4	394-15-03-000	MAIN BRAKE LINE ASSY-1/2"	1
5	394-15-00-110	BULKHEAD PLATE - 1 HOLE	1
6	R22656	KNOTT 2x60 CALIPER	4
7	R22659	17.5" OD CAST BRAKE ROTOR-16K	4
8	R23120	3/8"M X 3/8"M X 3/8" SW F JIC TEE	2
9	R23222	3/8" JIC BULKHEAD TEE	1
10	R23077	3/8" JIC F. x 1/2" JIC M. BUSHING	2
11	R07806	5/8 LOCK WASHER - ZINC	8
12	R07786	5/8-11 UNC HEX NUT - ZINC	8
13	R08502	5/8-11 UNC x 3 HEX BOLT GR.8	8
14	R08377	1/2-20 UNF x 4.5 SHCS - BLK	24
15	R07805	1/2 LOCK WASHER - ZINC	24
16	R23126	3/8" BSPP M. X 3/8" JIC M. ADAPTER	1
17	R23180	FASTER F. BRAKE COUPLING	1
18	R22149	ORB-5 x 3/8" JIC M. ADAPTER	4

BRAKE MODULATION KIT

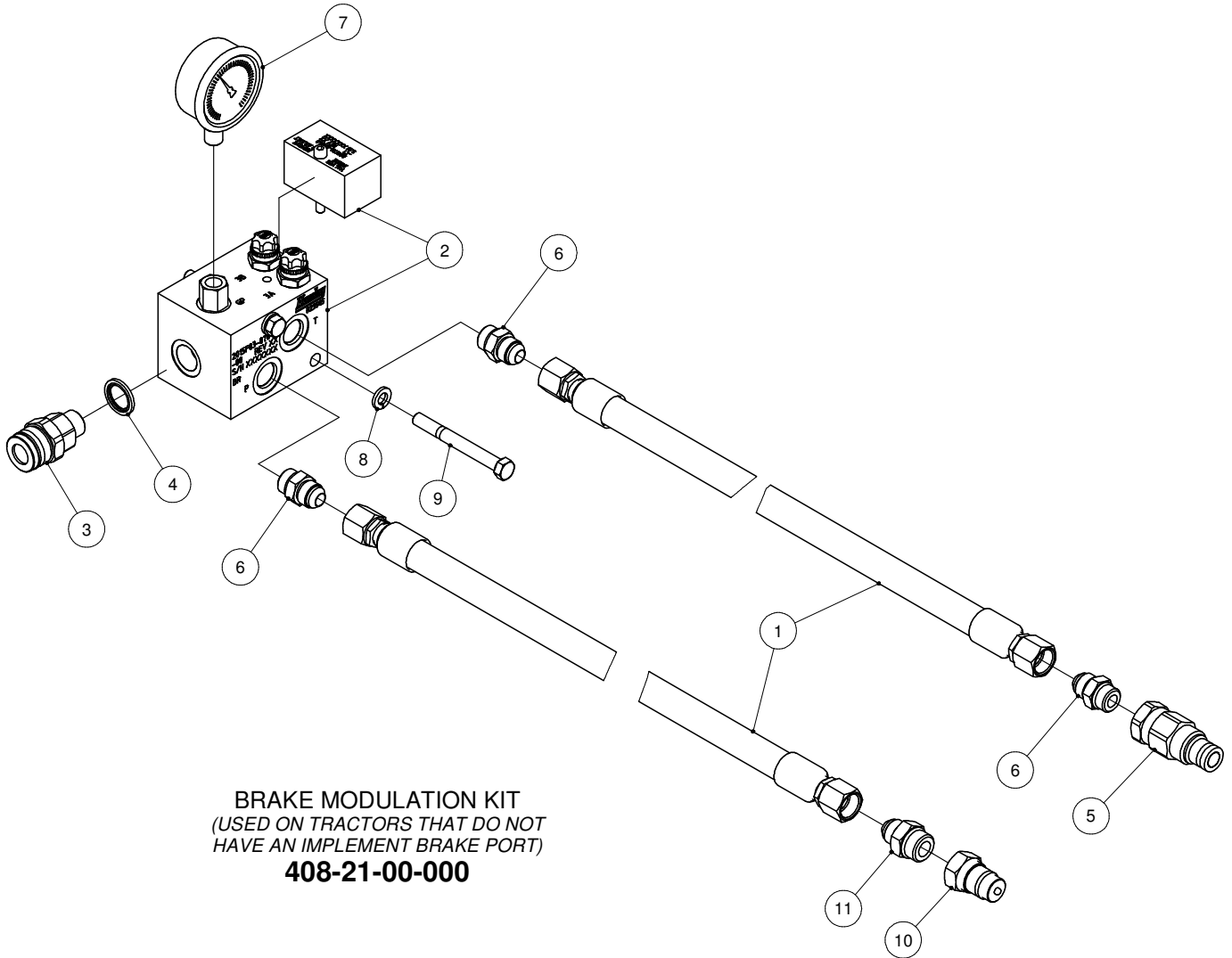

BRAKE MODULATION KIT
 (USED ON TRACTORS THAT DO NOT
 HAVE AN IMPLEMENT BRAKE PORT)
408-21-00-000

PARTS LIST			
ITEM	PART NUMBER	DESCRIPTION	QTY
1	408-21-01-000	HYD HOSE ASSY-MANIFOLD TO TRACTOR	2
2	R23505	BRAKE VALVE MANIFOLD-LYNCH	1
3	R23200	1/2" BSPP MALE FASTER COUPLING	1
4	R23148	1/2" BSPP BONDED SEAL	1
5	R23187	FASTER CASE DRAIN NIPPLE ORB-08	1
6	R23092	ORB-8 x 1/2" JIC M. ADAPTOR	3
7	R21251	2-1/2" SS PRESSURE GAUGE 3000 PSI	1
8	R07803	3/8 LOCK WASHER - ZINC	2
9	R07624	3/8-16 UNC x 3.5 HEX BOLT GR.5	2
10	R23182	MALE PIONEER TIP-ORB-10	1
11	R23095	ORB-10 x 1/2" JIC M ADAPTOR	1

This Page is Intentionally Left Blank

SPREADERS PTO - 2012

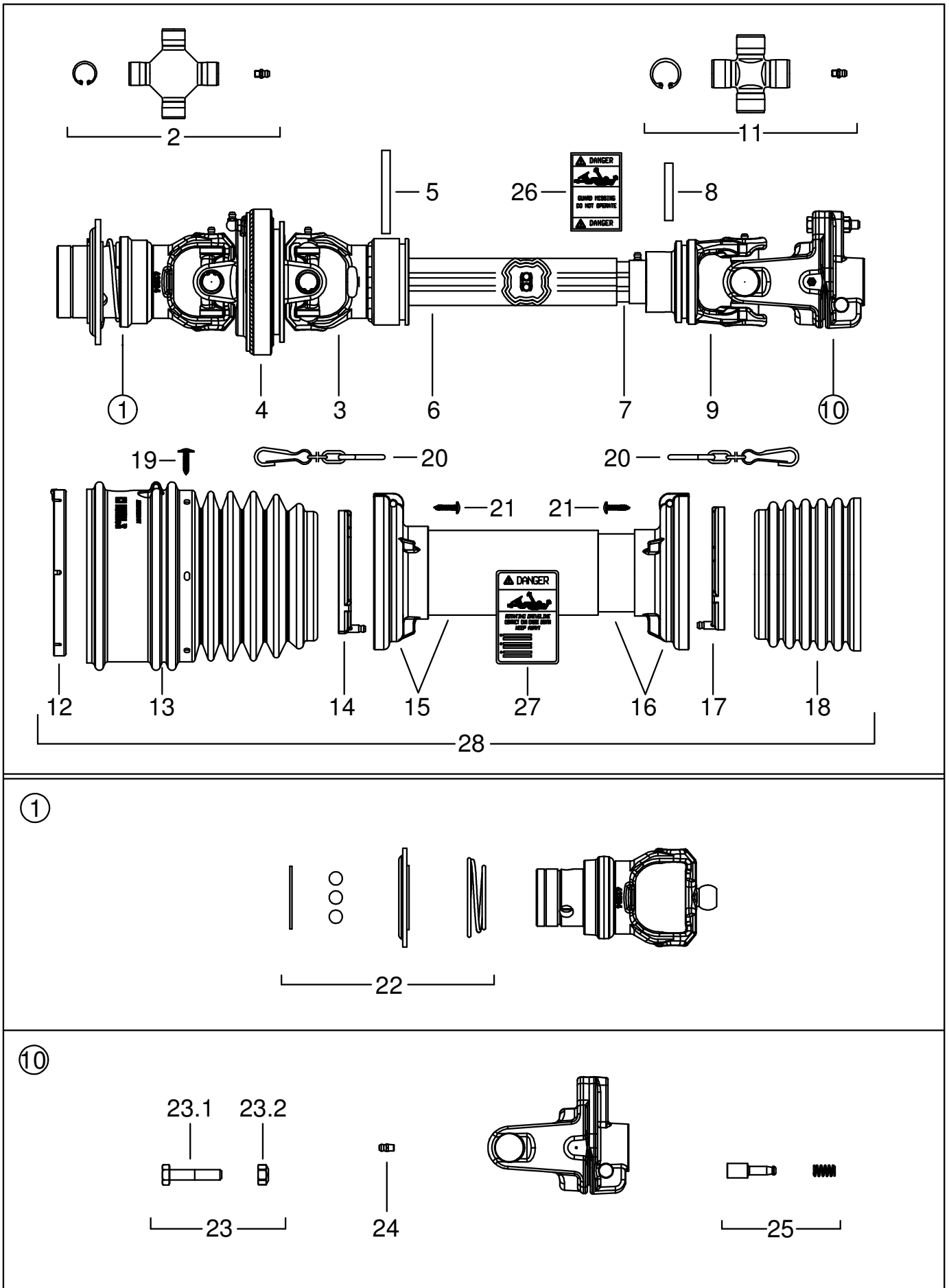

SPREADERS PTO - 2012

R21582 - 1 3/8" 6 TOOTH - 540 RPM

R21583 - 1 3/8" 21 TOOTH - 1000 RPM

R21584 - 1 3/4" 20 TOOTH - 1000 RPM

PARTS LIST				
ITEM	MFG #	PART NUMBER	DESCRIPTION	QTY
1	5730E0384	R22707	#4 1-3/8" CV YOKE - 6 TOOTH SLIDING YOKE COLLAR - 540rpm	1
	5730E3784	R22706	#4 1-3/8" CV YOKE - 21 TOOTH SLIDING YOKE COLLAR - 1000rpm	1
	5730E3884	R22708	#4 1-3/4" CV YOKE - 20 TOOTH SLIDING YOKE COLLAR - 1000rpm	1
2	4120E0051	R22709	#4 CROSS KIT - 22x86mm	2
3	2150E6871	R23381	#4 OUTER TUBE YOKE	1
4	5110E0052	R22711	#4 CENTRAL BODY-CV	1
5	341078000	R23382	FLEXIBLE ROLL PIN - 8x80mm	1
6	2253L1050	R23383	#4 OUTER DRIVE TUBE - L=1050mm	1
7	528S4R121WN	R23384	#4 INNER DRIVE TUBE - L=1075mm	1
8	341048000	R21476	FLEXIBLE ROLL PIN - 8x55mm	1
9	204S46853	R23385	#4 TUBE YOKE 4 LOBE - INNER	1
10	6060E0302	R22712	#4 SHEAR CLUTCH 1700Nm 1-3/8" 6T - PUSH PIN	1
11	4120E0012	R23386	#4 CROSS KIT - 27x74.6mm GREASE ZERK CAP	1
12	2550E0005	R23387	SHIELD OUTER BELL SUPPORT	1
13	2190E0121	R23388	CONE SHIELD BELL - OUTER	1
14	2550C0001	R23389	SHIELD SUPPORT - OUTER TUBE	1
15	5TWN3S4121U	R23390	#4 SHIELD TUBE & CONE - OUTER	1
16	5MWN3S4121U	R23391	#4 SHIELD TUBE & CONE - INNER	1
17	2550C0002	R23392	SHIELD SUPPORT - INNER TUBE	1
18	2190E0201	R23393	CONE SHIELD BELL - INNER	1
19	310001428	R22719	SCREW FLANGE HEAD - SELF TAP 4.8x22mm	6
20	252000050	R21738	SHIELD CHAIN w/ S-HOOK L=500mm	2
21	310001431	R23394	SCREW - SELF TAP 4.8x22mm	6
22	435000323	R22722	BALL COLLAR KIT 1-3/8" 6T & 1-3/8" 21T	1
	435000420	R22723	BALL COLLAR KIT 1-3/4" 20T	1
23	432000047	357-36-00-000	SHEAR BOLT & NUT - 5/PACK	1
23.1	-	R08251	M8x1.25x45 BOLT GR8.8 (NOT FOR INDIVIDUAL SALE)	1
23.2	-	R08252	M8x1.25 NYLOCK NUT (NOT FOR INDIVIDUAL SALE)	1
24	348017000	R21687	GREASE FITTING M6x1 STRAIGHT	1
25	403000001	R22724	COMPLETE PUSH PIN 1-3/8" 6T	1
26	399143000	R21523	DANGER SHIELD MISSING LABEL	1
27	399141000	R21521	DANGER ROTATING DRIVELINE LABEL	1
28	5CS4121U2WSG	R23395	COMPLETE SHIELD KIT	

HUSKY FARM EQUIPMENT LIMITED

ALMA, ON

NOB 1A0

PHONE: (519) 846-5329

FAX: (519) 846-9378

FIVE YEAR AXLE WARRANTY

Husky Farm Equipment Limited will guarantee for five (5) years from date of invoice, all Manure Spreader undercarriages and axle assemblies, if used on a farm for farm purposes.

Husky will replace free of charge:

1. Any part of the axle which should break or collapse through normal use.
2. Any spindles or hubs which should break through normal use.
3. Any wheel and rim assemblies which should fail through normal use.

Exempt from extended warranty are:

1. Any part of the axle which should break or collapse through overload. Overload includes: Any attachments (ie. injectors) and any product being transported in Spreader weighing more than 10 lb/gallon. (ie. manure mixed with sand).
2. Bearings and tires which are covered under normal warranty and do require maintenance to avoid failure.
3. Wheel or rim damage resulting from owner failing to keep wheel bolts tight.
4. Spindles damaged through bearing failure.
5. Any axle that is custom built.
6. Any axle used in commercial custom hauling applications.

To qualify for extended warranty, damaged parts must be returned to Husky Farm Equipment Limited, prepaid shipping, along with serial number and copy of the original invoice.

All parts supplied by Husky on warranty, will be shipped freight collect. Extended warranty covers damaged parts only and does not cause liability on Husky for any damage resulting from such failure.

TEN YEAR WARRANTY AGAINST RUSTOUT

Husky Farm Equipment provides a ten (10) year warranty from date of invoice, against premature perforation (rust out) of any liquid manure spreader manufactured. Providing the manure spreader is used for manure or sludge and not for chemical products.

Extended warranty is pro rated and will be paid only through the crediting off of the then current list price of a replacement manure spreader of the portion of warranty not used up in time.

Warranty will be effective toward replacing spreader only and no cash payment will be made. It will be understood that the original equipment to be replaced will then become property of Husky Farm Equipment Limited.

This extended warranty will be effective through Husky Farm Equipment factory or factory outlet only. A copy of the original invoice is to be supplied along with the serial number. This warranty will not be effective for commercial custom haulers or to owners other than the original.

Transportation to and from the factory is to be paid for by the owner of the equipment and not by Husky Farm Equipment Limited.